

...the Leader in Refrigeration Innovation



Temprite®

www.temprite.com

email: temprite@temprite.com

1555 West Hawthorne Lane, Suite 1E
West Chicago, Illinois 60185-1822 USA

1.800.552.9300

Phone: 630.293.5910
Fax: 630.293.9594



Temprite®

Temprite specializes in innovative, energy-efficient coalescent and conventional oil separators, and refrigerant oil management products including oil level controls and oil reservoirs.



Every Temprite product is engineered and manufactured to enhance total thermal efficiency while reducing carbon emissions and providing the highest possible return on investment. Temprite products are the solution to rising energy costs, longer system life and reduced carbon emissions. Each component is designed to make refrigeration systems clean and green.

Founded in 1924, Temprite was a pioneer in the refrigeration industry and one of the first companies to specialize in refrigeration components. Early Temprite products included beer coolers and dispensing valves for soda fountains and water coolers.

The Temprite reputation for innovation arose when the company originated some of the earliest refrigeration components including the conventional oil separator in its current configuration: Every conventional oil separator is a copy of a Temprite oil separator.

In 1988, Temprite was the first company to design and manufacture coalescent oil separators and oil reservoirs with the introduction of the high-efficiency 900 Series. The 920 & 920R Series were developed in 1990-1991 to meet customer needs for energy savings, lower carbon emissions and increased system life.

Today, Temprite is a premier brand name in the industry. Building on decades of experience in manufacturing components for the refrigeration industry, the Temprite tradition of innovation continues with energy-efficient coalescent and conventional oil separators for every type of refrigerant, such as the 130 Series for CO₂ and the ammonia-compatible 920 & 920R Series.

Temprite's Commitment to Customers

Temprite will provide the highest quality refrigeration component products—as well as the best operational specifications—available worldwide.

Product Certifications

Since December 2001, all products conform to the European Pressure Directive (PED). As customer refrigeration systems can vary greatly, each Temprite product is tested both on in-house test beds and in the field, using a variety of parameters. Every time there's a new standard to meet, Temprite products help customers meet it. All Temprite components are certified by at least one of the following notified bodies: UL, ULC, CE, CRN, KHK and ASME.*



*Contact Temprite for individual product certifications.

International Distribution

The Temprite plant is located in West Chicago, Illinois, USA, with distribution facilities in Tokyo, Japan; Glasgow, UK; Stuttgart, Germany; Ankara, Turkey; Bangalore, India; and Sydney, Australia. Temprite has worldwide distribution through wholesalers and direct sales to original equipment manufacturers, retailers and medical organizations, and through strategic partners in the United Kingdom, Japan, Germany, Turkey, India and Australia.

Temprite Coalescent Oil Separators

4

130 Series for CO₂: Model 131: Hermetic; Models 133A-139A: Accessible
 300 Series: Hermetic; Models 320-322, 340-343
 900 Series: Hermetic; Models 900, 900-1, 902-905
 920 & 920R Series*: Accessible; Models 922-930 & 922R-930R

Temprite Conventional Oil Separators

14

500 Series: Accessible; Models 501-505, 506, 507
 600 Series: Hermetic; Models 600-605, 606, 607

Sizing Charts

16

920 & 920R Series: Tons
 920 & 920R Series: kW
 920 & 920R Series: Natural Refrigerants
 300 & 900 Series
 500 & 600 Series
 130 Series for CO₂
 Quick Reference Chart

Oil Management

23

Oil Level Controls: Mechanical
 Oil Reservoirs: 47058, 47080, 47115, 47154
 Oil Reservoirs for CO₂: RES 7, RES 17
 Oil Return Floats
 Valves: A-7, OCV-20, Rotalock Valve, Y1236C
 HB products for CO₂: Oil Sensors & Switches: HBOC, HBSO1, HPBA, V100
 TraxOil Electronic Oil Level Controls
 TraxOil Oil Watches

Optional Items

32

Pressure Differential Indicator (PDI)
 Filter/Drier Shells for CO₂

Replacement Parts

33

130 Series Standard Filter Kits, Clean-Up® Filter Kits
 920 & 920R Series Standard Filter Kits, Clean-Up® Filter Kits
 Screen Kits, Bottom & Top Plate Gaskets/O-Rings, O-Ring/Gasket Kits
 Float & Plate Assemblies, Sight Glasses

*Ammonia and subcritical CO₂ compatible

Filtration & Separation

All Temprite coalescent oil separators are equipped with a Standard Filter that uses a matrix-type borosilicate glass fiber material to do the work formerly done by impingement screens in conventional oil separators.

Illustration #1 shows how a coalescent oil separator moves oil-laden refrigerant gas into the filter and through the separator. Refrigerant pressure moves the aerosolized oil into the separator. Oil droplets separate as they enter the filter, where the oil is stripped from the refrigerant gas. These larger, heavier droplets accumulate at the edge of the filter and fall, collecting at the bottom of the separator where the clean oil is returned to the compressor. The clean refrigerant gas moves upward to the condenser.

Illustration #2 shows a cross-section of a Temprite Standard Filter. System pressure moves the refrigerant oil in aerosol form outward from the center of the filter. The filter's borosilicate fiber matrix causes the aerosolized oil to collide with other oil droplets, creating bigger oil droplets. The oil droplets are pushed to the outer edges of the filter by refrigerant flow, and fall to the bottom of the separator.

Illustration #1: Oil Separator Cross Section

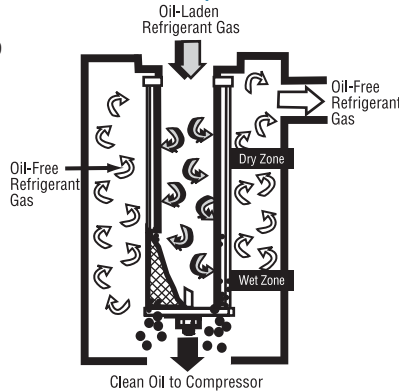
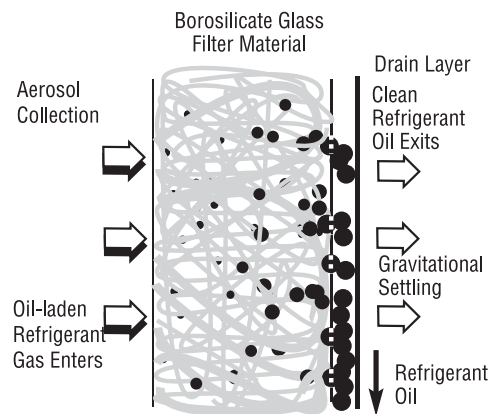

Illustration #2: Standard Filter Cross Section



Typical Aerosol Distribution in Mass Flow

Illustration #3: Aerosol Distribution

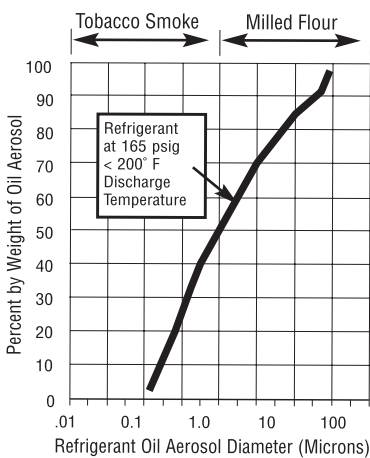

Illustration #3 shows micron particle sizes in a typical aerosol distribution ranging from .01 to 100 microns (μm) in size. Tobacco smoke and milled flour particle sizes are given as a reference point. The majority of oil droplets in refrigerant discharge gas are in the 0.4 to 10 μm range, with more than 50% of the droplets less than 1 μm in size. When evaluating the efficiency of your current separator, compare the micron cleaning range of your separator to Temprite coalescent oil separators. The exceptional Temprite Standard Filter technology cleans contaminants down to 0.3 microns in size.

Exceptional Contaminant Removal

Two of the biggest energy drains on any refrigeration system are dirt, contaminants and excess refrigerant oil. Refrigerants also have an enhanced solvent effect, meaning more contaminants than ever can be clogging your system.

Illustration #4 compares the filtration levels of all other types of separators to coalescent oil separators. Temprite filtration gives you the cleanest possible oil and refrigerant gas—the keys to energy efficiency, lower carbon emissions, longer compressor life and lower energy costs.

Illustration #4: Coalescent Oil Separator Filtration Level

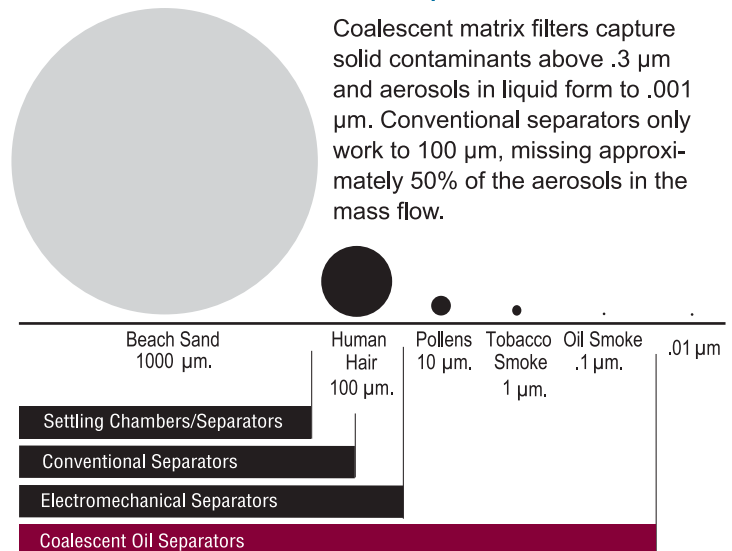

Temprite Technology

Temprite's coalescent oil separators (COS) set the industry standard for energy-efficient performance. Unlike conventional separators, coalescent oil separators are not dependent on velocity for efficiency, maintaining the same level of effectiveness down to 20% of maximum flow.

- The high-efficiency performance of coalescing oil separators means better heat transfer through the coils, translating into significant kW savings.
- Coalescent oil separators are ideal for OEM applications where system cleanliness is paramount.

Exceptional Performance Range

Temprite products are engineered and manufactured to improve refrigeration and system thermal efficiency by minimizing oil and dirt in the system's evaporator. This results in shorter compressor run times, reduced carbon emissions and energy consumption, and the highest possible return on investment.

- Temprite coalescent oil separators separate and clean oil at a nominal 98.5%+ efficiency level.
- Coalescent oil separators maintain the same level of effectiveness down to 20% of mass flow.

Natural Refrigerant Conversions

Changing to environmentally friendly refrigerants is a mandate in most countries. Make your system as clean and green as possible by converting or retrofitting with Temprite coalescent oil separators.

130 Series for CO₂: Hermetic and Accessible

Temprite technology addresses the unique and challenging demands of CO₂ systems. Building on the best attributes of Temprite's 920 and 920R Series* oil separation technology, the 130 Series of coalescent oil separators is designed specifically for transcritical CO₂ systems and optimized for transcritical refrigeration applications.

*Both the 920 & 920R Series have been used extensively in subcritical applications up to 45 bar (650 PSI) for many years.

The 130 Series are the first coalescing oil separators created for transcritical CO₂ to undergo performance testing at internationally recognized testing organizations and have proven to perform the best of any filtration and separation technology. In addition to a range of six different sizes of separators, Temprite developed reservoirs and filter/drier shells specifically for transcritical CO₂ applications.



130 Series Technology

Specifications

- Application range: suitable for R744 (CO₂) transcritical high-, medium- and low-temperature applications
- Dual function: filters dirt out of the refrigerant and oil; separates the oil from the refrigerant gas
- Maximum operating pressure: 130 bar (1885 PSI)
- Efficiency: nominal 98.5%+ separation efficiency rating
- Filtration: Sub-micron particulate retention rating
- Connection sizes: 1/2" NPT to 2" NPT or Butt Weld

Advantages

High Efficiency: most efficient oil-refrigerant filtering/separation technology with a 98.5%+ separation efficiency rating across the widest range of mass flows.

Energy-Saving: minimizes the amount of oil in the evaporator, improving heat transfer efficiency.

Cost-Saving: ensures shorter compressor run times.

Easy Filter Changing: removable top plate allows for easy filter changing after it captures excess dirt circulating in the system.*

Individually Adjustable Mounting Feet: allow for variable field leveling and adjustment.

Internal Oil Level Monitoring: the integral oil reservoir and sensor port allows monitoring of the internal oil level and the controlled return of the cleaned oil to the compressor crank case for continued lubrication of the moving parts.

*Model 131 is hermetic and the filter is not accessible for changing.

CO₂4U™

Temprite engineers continue to work with customers and specialists in the CO₂ field to develop products that work with the leading refrigeration technology.

Let us know what you need for your CO₂ system. We can produce liquid receivers and other high-pressure components for CO₂ applications to meet customer requirements.

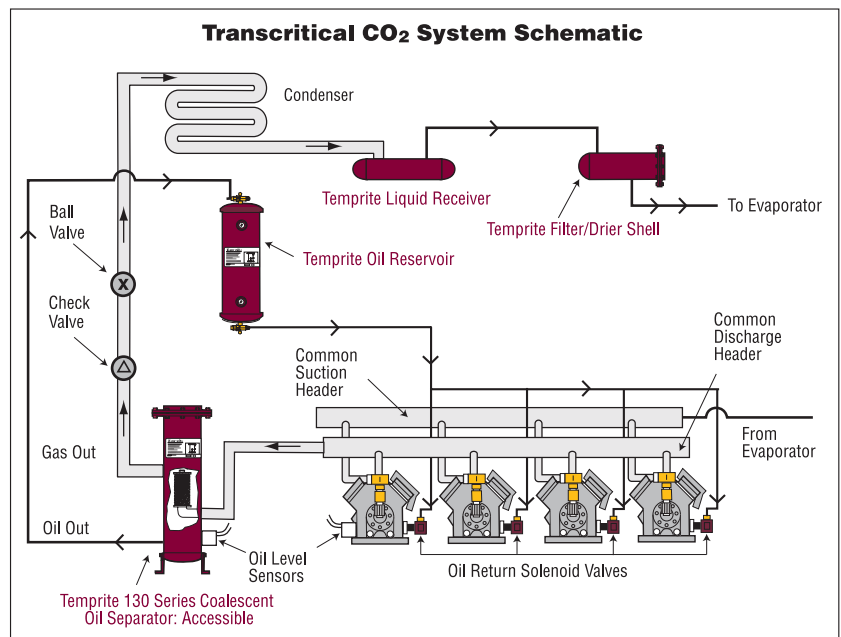

Temprite® Coalescent Oil Separators

130 Series for CO₂

Maximum Working Pressure: 130 bar (1885 PSI)

Model 131: Hermetic

Part #	Model #	A Dim.	B Dim.	C Dim.	D Dim.
		Inlet/Outlet/ Oil Connector	Outlet Location	Height	Diameter
013101310	131	1/4" FPT*	115 mm 4.5"	165 mm 6.5"	73 mm 2.9"

*FPT=Female Pipe Thread, MPT=Male Pipe Thread, BW=Butt Weld

SELECT OIL SEPARATOR WITH CONNECTION SIZE NOT LESS THAN DISCHARGE LINE SIZE

NOTE: See page 10 for the 920 & 920R Series of products, suitable for subcritical applications up to 44.8 bar (650 PSI). The 920 & 920R Series are also ammonia compatible.

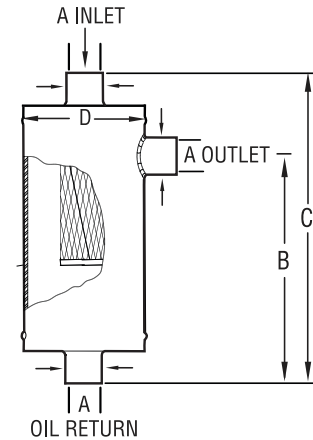

Models 133A, 135A, 137A: Accessible

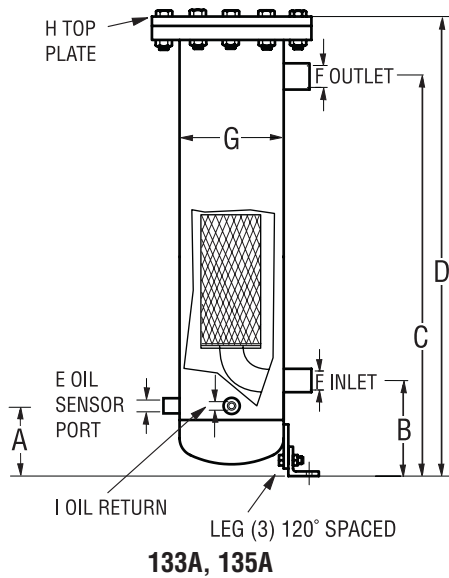

133A, 135A

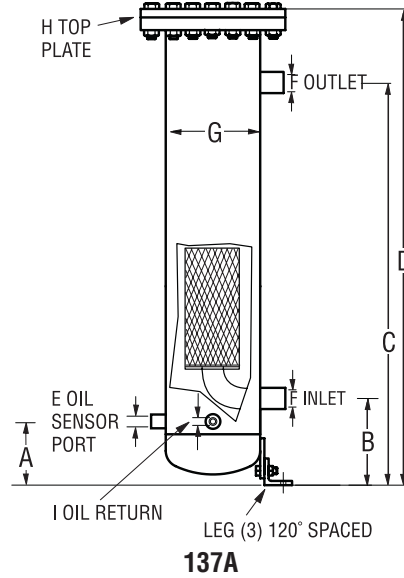

137A

Part #	Model # Inlet/ Outlet	A Dim.	B Dim.	C Dim.	D Dim.	E Dim.	F Dim.	G Dim.	H Dim.	I Dim.
		Sensor/ Oil Loc.	Inlet Loc.	Outlet Loc.	Height	Sensor	Inlet/ Outlet	Dia.	Dia.	Oil Return
013301330	133A 1/2" MPT*	118 mm 4.6"	152 mm 6"	325 mm 12.8"	435 mm 17"	3/4" FPT*	1/2" MPT*	102 mm 4.0"	176 mm 6.9"	1/4" FPT*
013301331	133A 1/2" BW*	118 mm 4.6"	152 mm 6"	325 mm 12.8"	435 mm 17"	3/4" FPT*	1/2" BW*	102 mm 4.0"	176 mm 6.9"	1/4" FPT*
013501350	135A 3/4" MPT*	118 mm 4.6"	152 mm 6"	433 mm 17.1"	545 mm 21.4"	3/4" FPT*	3/4" MPT*	102 mm 4.0"	176 mm 6.9"	1/4" FPT*
013501351	135A 3/4" BW*	118 mm 4.6"	152 mm 6"	433 mm 17.1"	545 mm 21.4"	3/4" FPT*	3/4" BW*	102 mm 4.0"	176 mm 6.9"	1/4" FPT*
013710142	137A 1" MPT*	131 mm 5.1"	171 mm 6.7"	584 mm 23"	702 mm 27.6"	3/4" FPT*	1" MPT*	141 mm 5.56"	216 mm 8.5"	1/4" FPT*
013701375	137A 1" BW*	131 mm 5.1"	171 mm 6.7"	584 mm 23"	702 mm 27.6"	3/4" FPT*	1" BW*	141 mm 5.56"	216 mm 8.5"	1/4" FPT*
013701370	137A 1-1/4" MPT*	131 mm 5.1"	171 mm 6.7"	584 mm 23"	702 mm 27.6"	3/4" FPT*	1-1/4" MPT*	141 mm 5.56"	216 mm 8.5"	1/4" FPT*
013701371	137A 1-1/4" BW*	131 mm 5.1"	171 mm 6.7"	584 mm 23"	702 mm 27.6"	3/4" FPT*	1-1/4" BW*	141 mm 5.56"	216 mm 8.5"	1/4" FPT*

* FPT=Female Pipe Thread, MPT=Male Pipe Thread, BW=Butt Weld

SELECT OIL SEPARATOR WITH CONNECTION SIZE NOT LESS THAN DISCHARGE LINE SIZE.

NOTE: See page 10 for the 920 & 920R Series of products, suitable for subcritical applications up to 44.8 bar (650 PSI). The 920 & 920R Series are also ammonia compatible.

130 Series for CO₂

Maximum Working Pressure: 130 bar (1885 PSI)

Model 138A: Accessible

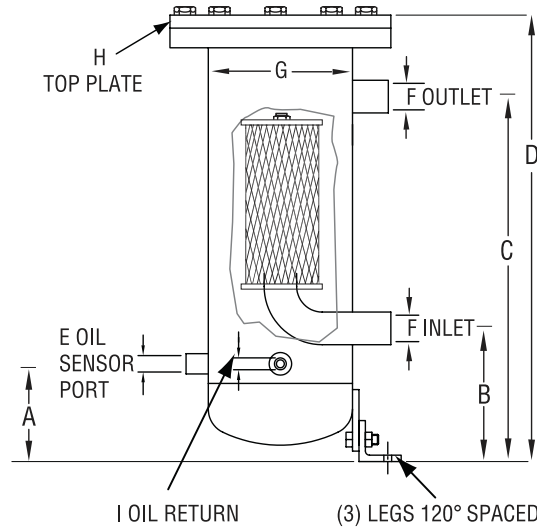

138A

Part #	Model # Inlet/ Outlet	A Dim.	B Dim.	C Dim.	D Dim.	E Dim.	F Dim.	G Dim.	H Dim.	I Dim.
		Oil Sensor/ Port	Inlet	Outlet	Height	Sensor	Inlet/ Outlet	Dia.	Dia.	Oil Return
013801380	138A 1-1/2" MPT*	131 mm 5.1"	171 mm 6.7"	752 mm 29.6"	870 mm 34.2"	3/4" FPT*	1-1/2" MPT*	141 mm 5.6"	216 mm 8.5"	1/4" FPT*
013801381	138A 1-1/2" BW*	131 mm 5.1"	171 mm 6.7"	752 mm 29.6"	870 mm 34.2"	3/4" FPT*	1-1/2" BW*	141 mm 5.6"	216 mm 8.5"	1/4" FPT*

* FPT=Female Pipe Thread, MPT=Male Pipe Thread, BW=Butt Weld

Model 139A: Accessible

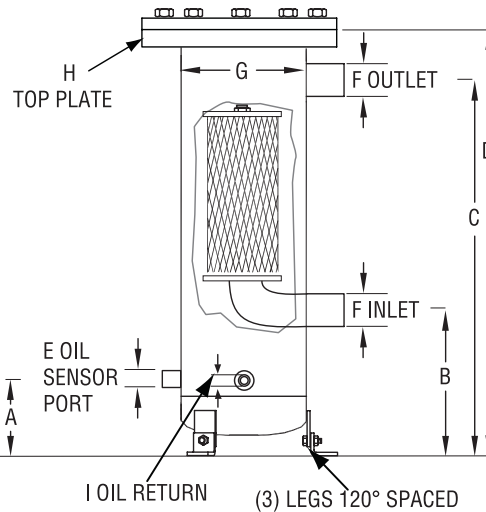

139A

Part #	Model # Inlet/ Outlet	A Dim.	B Dim.	C Dim.	D Dim.	E Dim.	F Dim.	G Dim.	H Dim.	I Dim.
		Sensor/ Oil Loc.	Inlet Loc.	Outlet Loc.	Height	Sensor	Inlet/ Outlet	Dia.	Dia.	Oil Return
013911391	139A 1-1/2" BW*	162 mm 6.4"	210 mm 8.3"	765 mm 30.1"	927 mm 36.5"	3/4" FPT*	1-1/2" BW*	219 mm 8.6"	324 mm 12.75"	1/4" FPT*
013921392	139A 2" BW*	162 mm 6.4"	210 mm 8.3"	765 mm 30.1"	927 mm 36.5"	3/4" FPT*	2" BW*	219 mm 8.6"	324 mm 12.75"	1/4" FPT*

* FPT=Female Pipe Thread, MPT=Male Pipe Thread, BW=Butt Weld

SELECT OIL SEPARATOR WITH CONNECTION SIZE NOT LESS THAN DISCHARGE LINE SIZE.

NOTE: See page 10 for the 920 & 920R Series of products, suitable for subcritical applications up to 44.8 bar (650 PSI).
The 920 & 920R Series are also ammonia compatible.

Temprite® Coalescent Oil Separators

300 Series: Hermetic

Maximum Working Pressure: 44.8 bar (650 PSI)

Temprite's 300 Series of hermetic coalescent oil separators are one of the smallest oil separators available for their capacity.

- 320 and 340 Series units are 99.995% efficient in removing particulates between 0.3 and 0.6 microns (μm) and separating oil from the mass flow. The elimination of the float ball and internal oil reservoir maximizes efficiency by minimizing oil carryover.

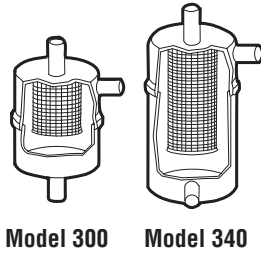

- Metering the oil return back to the compressor may be done by a variety of methods including a capillary tube, a metered orifice or a timed solenoid.

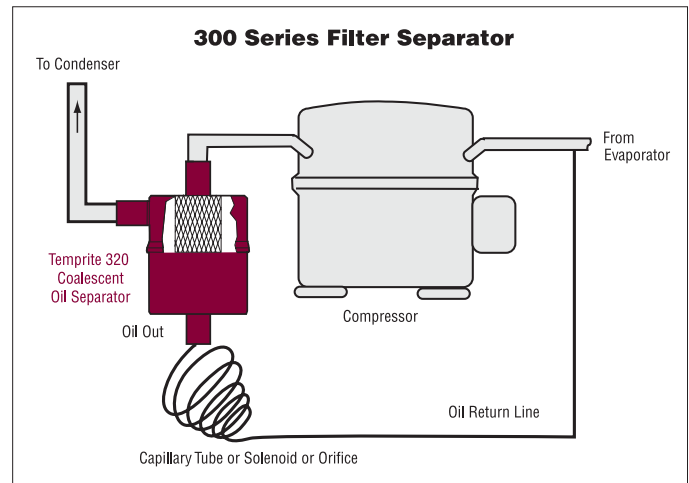

Models 320-322

Part #	Model #	A Dim./Oil Conn. Size	B Dim.	C Dim.	D Dim.
032000000	320	3/8" ODS* 9.53 mm	2-1/16" 52 mm	4-1/4" 108 mm	2-1/2" 64 mm
032100000	321	1/8" FPT*	2-1/16" 52 mm	3-1/2" 89 mm	2-1/2" 64 mm
032200000	322	1/4" SAE*	2-1/16" 52 mm	4" 102 mm	2-1/2" 64 mm

* FPT = Female Pipe Thread, MPT = Male Pipe Thread, ODS= Gas inlet and outlet connections are female solder bosses to receive O.D. tube size, SAE = Flare Connection

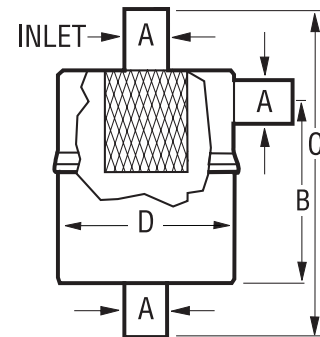

Models 340-342

Part #	Model #	A Dim./ Oil Conn. Size	B Dim.	C Dim.	D Dim.
034000000	340	3/8" ODS* 9.53 mm	3-9/16" 90 mm	4-7/8" 124 mm	2-1/2" 64 mm
034100000	341	1/8" FPT*	3-9/16" 90 mm	4-1/2" 114 mm	2-1/2" 64 mm
034200000	342	1/4" SAE*	3-9/16" 90 mm	4-3/4" 121 mm	2-1/2" 64 mm
034300000	343	3/8" SAE*	3-9/16" 90 mm	4-15/16" 125 mm	2-1/2" 64 mm

* FPT = Female Pipe Thread, MPT = Male Pipe Thread, ODS= Gas inlet and outlet connections are female solder bosses to receive O.D. tube size, SAE = Flare Connection

SELECT OIL SEPARATOR WITH CONNECTION SIZE NOT LESS THAN DISCHARGE LINE SIZE.

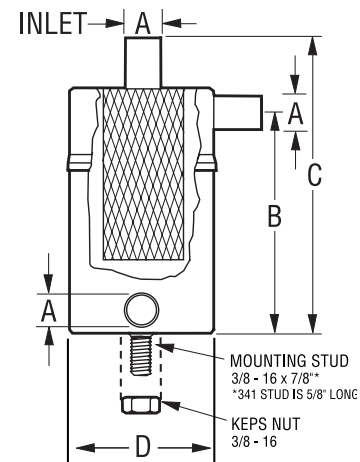

900 Series: Hermetic

Maximum Working Pressure: 44.8 bar (650 PSI)

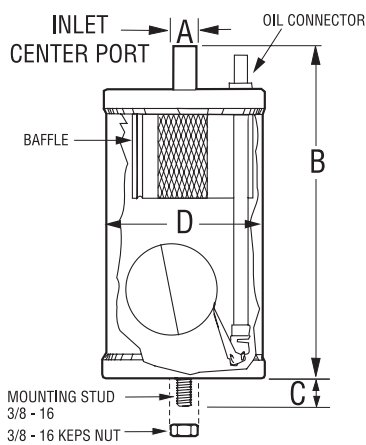

900, 900-1, 901

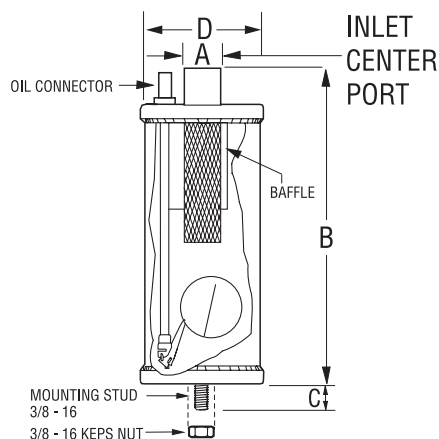

902, 903

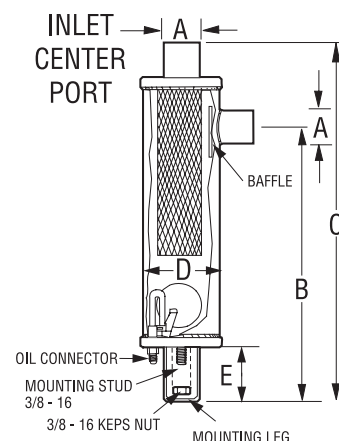

904, 905

Models 900, 900-1, 901

Part #	Model #	Oil Conn. Size	A Dim.	B Dim.	C Dim.	D Dim.	Oil Charge Amt.
090000000	900	1/4" ODS 6.35 mm	3/8" ODS 9.53 mm	8-1/4" 210 mm	3/4" 19 mm	4" 102 mm	15 oz. 445 ml.
090081000	900-1	1/4" 90° ODS 6.35 mm	3/8" ODS 9.53 mm	8-1/4" 210 mm	3/4" 19 mm	4" 102 mm	15 oz. 445 ml.
090100000	901	1/4" ODS 6.35 mm	1/2" ODS 12.70 mm	8-3/8" 213 mm	3/4" 19 mm	4" 102 mm	15 oz. 445 ml.

Models 902, 903

Part #	Model #	Oil Conn. Size	A Dim.	B Dim.	C Dim.	D Dim.	Oil Charge Amt.
090200000	902	1/4" ODS 6.35 mm	5/8" ODS 15.88 mm	10-9/16" 268 mm	3/4" 19 mm	4" 102 mm	15 oz. 445 ml.
090300000	903	1/4" ODS 6.35 mm	7/8" ODS 22.23 mm	10-7/8" 276 mm	3/4" 19 mm	4" 102 mm	15 oz. 445 ml.

Models 904, 905

Part #	Model #	Oil Conn. Size	A Dim.	B Dim.	C Dim.	D Dim.	E Dim.	Oil Charge Amt.
090400000	904	1/4" ODS 6.35 mm	1-1/8" ODS 28.58 mm	15-1/8" 384 mm	18-3/8" 467 mm	4" 102 mm	3" 76 mm	16 oz. 475 ml.
090500000	905	1/4" ODS 6.35 mm	1-3/8" ODS 34.93 mm	15-1/8" 384 mm	18-3/8" 467 mm	4" 102 mm	3" 76 mm	16 oz. 475 ml.

SELECT OIL SEPARATOR WITH CONNECTION SIZE NOT LESS THAN DISCHARGE LINE SIZE.

920 & 920R Series Coalescent Oil Separators: Accessible



920 Series



920R Series

Lower Energy Costs & Carbon Emissions

The energy-efficient 920 & 920R Series of coalescent oil separators are designed for maximum energy-efficiency. Temprite separators make refrigeration systems clean and green by lowering energy costs and reducing carbon emissions.

The 920R Series delivers the:

- Highest measured capacity of refrigeration.
- Lowest kilowatts required per unit of cooling (per ton).

All 920 & 920R separators perform with equal efficiency in all types of systems:

- in ultra-low temperature applications;
- even or uneven multiplex systems, dual-suction systems, low, medium and A/C; and
- during refrigeration load shifting/matching.

Large-Scale Refrigeration Cost Savings

In large parallel rack/multiplex systems with long lines, dirt and excess oil put an even greater drag on system efficiency.

- Both problems are eliminated with the 920 & 920R Series separators, increasing system capacity and efficiency and lowering energy costs.
- Energy savings scale up with larger systems.

Ammonia (NH₃) Compatible

Both 920 & 920R Series separators are ammonia (NH₃) compatible and designed for 650 PSI. Because ammonia is a cleaning agent, more dirt is removed from the system and deposited in the filter.

920 & 920R separators offer easy accessibility to the Temprite Standard Filter for changes. Other products require disassembling and re-welding the separator for filter changes.

External Reservoir

All 920 Series models are designed for use with an external reservoir.

“R” is For Reservoir

An oil reservoir is built into each 920R Series coalescent oil separator. The built-in reservoir reduces piping, components and potential leaks and creates a stable, high-pressure oil system.

Because the oil reservoir is built-in, 920R Series separators do not have a float.



920 & 920R Cost & Energy Savings

Properly designed coalescing separators remove 95% to 99% of the oil from a system's mass flow while maintaining the same level of effectiveness regardless of system velocities and loads. This is especially important for large-scale refrigeration systems: 60% of a grocery store's cost of operation is refrigeration. Temprite's 920 & 920R Series Cost Savings Calculator allows you to see how much energy and money you'll save based on your system, price of energy, run days and total capacity. You'll see how savings increase based on the number of stores, both annually and for the 10-year life of system, and how carbon emissions are also reduced. Visit www.temprite.com to find out how much you can save.

920 & 920R Series: Accessible

Maximum Working Pressure: 44.8 bar (650 PSI)

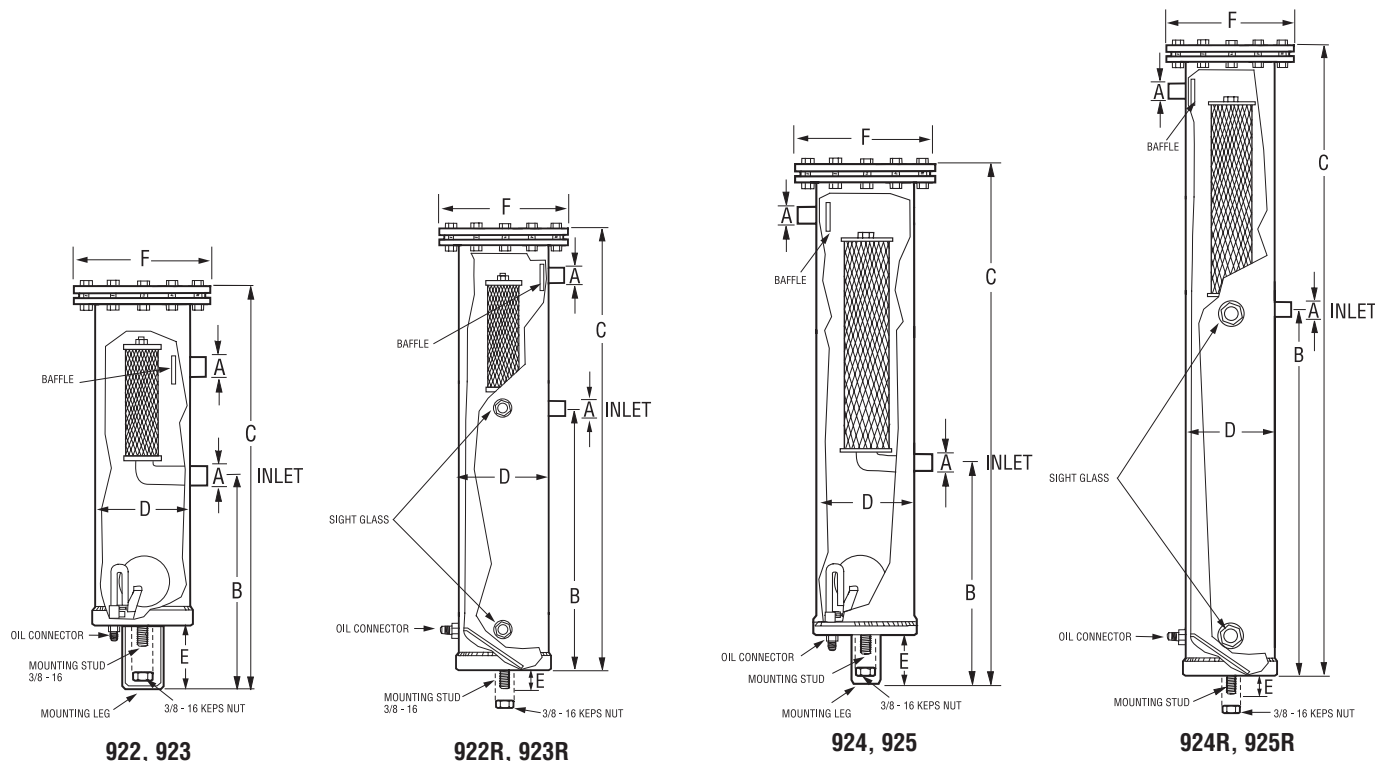

Models 922, 923, 922R, 923R

Part #	Model #	Oil Conn. Size	A Dim.	B Dim.	C Dim.	D Dim.	E Dim.	F Dim.	Oil Charge Amt.
092200000	922	1/4" SAE	5/8" ODS 15.88 mm	9-3/8" 238 mm	17-1/4" 438 mm	4" 102 mm	3" 76 mm	6-1/2" 165 mm	16 oz. 475 ml.
092300000	923	1/4" SAE	7/8" ODS 22.23 mm	9-3/8" 238 mm	17-1/4" 438 mm	4" 102 mm	3" 76 mm	6-1/2" 165 mm	16 oz. 475 ml.
092201000	922R	1/4" SAE	5/8" ODS 15.88 mm	11-5/8" 295 mm	19-1/2" 495 mm	4" 102 mm	3/4" 19 mm	6-1/2" 165 mm	77 oz. 2.27 Liters
092301000	923R	1/4" SAE	7/8" ODS 22.23 mm	11-5/8" 295 mm	19-1/2" 495 mm	4" 102 mm	3/4" 19 mm	6-1/2" 165 mm	77 oz. 2.27 Liters

Models 924, 925, 924R, 925R

Part #	Model #	Oil Conn. Size	A Dim.	B Dim.	C Dim.	D Dim.	E Dim.	F Dim.	Oil Charge Amt.
092400000	924	1/4" SAE	1-1/8" ODS 28.58 mm	9-3/8" 238 mm	21-5/8" 549 mm	4" 102 mm	3" 76 mm	6-1/2" 165 mm	16 oz. 475 ml.
092500000	925	1/4" SAE	1-3/8" ODS 34.93 mm	9-3/8" 238 mm	21-5/8" 549 mm	4" 102 mm	3" 76 mm	6-1/2" 165 mm	16 oz. 475 ml.
092401000	924R	1/4" SAE	1-1/8" ODS 28.58 mm	16-3/8" 416 mm	28-5/8" 727 mm	4" 102 mm	3/4" 19 mm	6-1/2" 165 mm	109 oz. 3.22 Liters
092501000	925R	1/4" SAE	1-3/8" ODS 34.93 mm	16-3/8" 416 mm	28-5/8" 727 mm	4" 102 mm	3/4" 19 mm	6-1/2" 165 mm	109 oz. 3.22 Liters

Temprite® Coalescent Oil Separators

920 & 920R Series: Accessible

Models, 926, 927, 926R, 927R

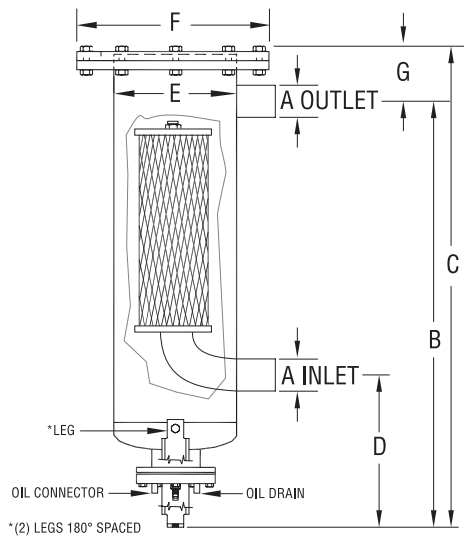

926, 927

Maximum Working Pressure: 44.8 bar (650 PSI)

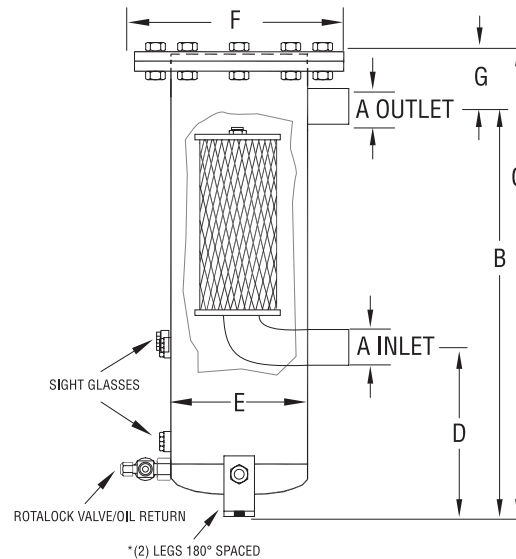

926R, 927R

Part #	Model #	Oil Conn. Size	A Dim.	B Dim.	C Dim.	D Dim.	E Dim.	F Dim.	G Dim.	Oil Charge Amt.
092600000	926	3/8" SAE	1-5/8" ODS 41.28 mm	29-7/16" 748 mm	35" 889 mm	12" 305 mm	6" 152 mm	8-1/2" 216 mm	4-1/2" 114 mm	34 oz. 1 Liters
092700000	927	3/8" SAE	2-1/8" ODS 53.98 mm	29-7/16" 748 mm	35" 889 mm	12" 305 mm	6" 152 mm	8-1/2" 216 mm	4-1/2" 114 mm	34 oz. 1 Liters
092601000	926R	3/8" SAE	1-5/8" ODS 41.28 mm	33-7/8" 860 mm	38-3/8" 975 mm	16-5/8" 422 mm	6" 152 mm	8-1/2" 216 mm	4-1/2" 114 mm	1.8 Gal. 6.7 Liters
092701000	927R	3/8" SAE	2-1/8" ODS 53.98 mm	33-7/8" 860 mm	38-3/8" 975 mm	16-5/8" 422 mm	6" 152 mm	8-1/2" 216 mm	4-1/2" 114 mm	1.8 Gal. 6.7 Liters

Models 928, 928R

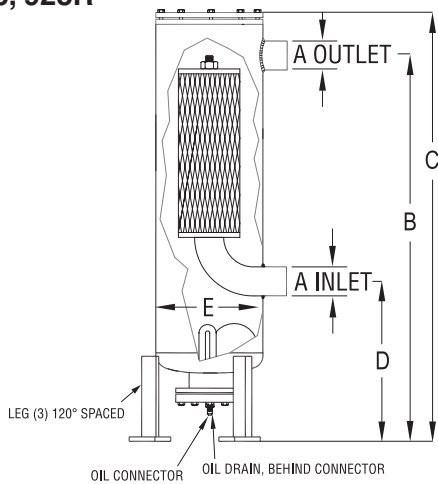

928

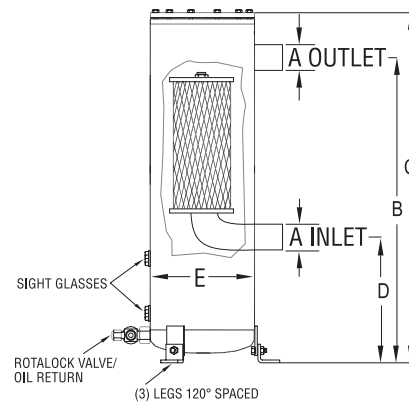

928R

Part #	Model #	Oil Conn. Size	A Dim.	B Dim.	C Dim.	D Dim.	E Dim.	Oil Charge Amt.
092800000	928	3/8" SAE	2-5/8" ODS 67 mm	33-5/8" 854 mm	39-1/2" 1003 mm	12-3/4" 324 mm	8-5/8" 219 mm	34 oz. 1 Liters
092801000	928R	3/8" SAE	2-5/8" ODS 67 mm	32-3/8" 822 mm	37" 940 mm	11-1/2" 292 mm	8-5/8" 219 mm	2.0 Gal. 7.55 Liters

920 & 920R Series: Accessible

Maximum Working Pressure: 44.8 bar (650 PSI)

Models 930, 930R

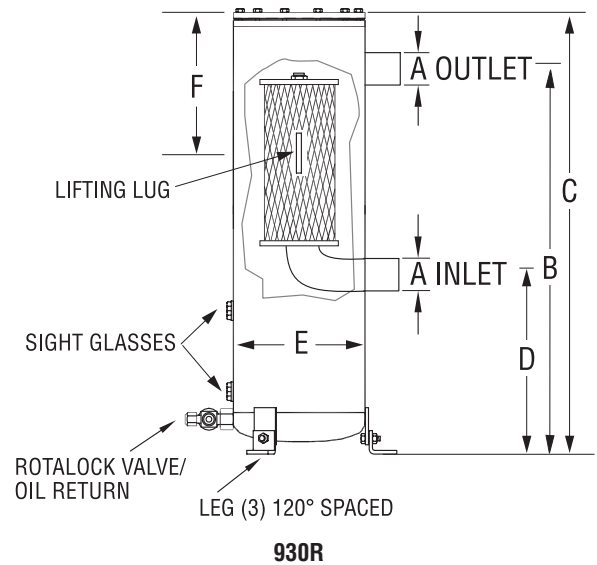
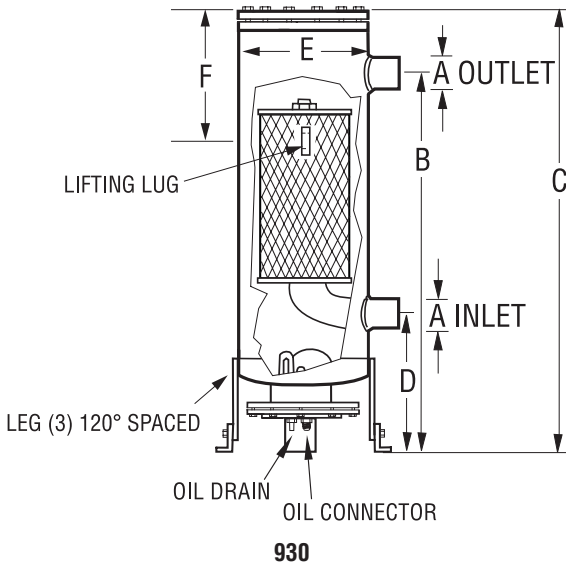

Part #	Model #	Oil Conn. Size	A Dim.	B Dim.	C Dim.	D Dim.	E Dim.	F Dim.	Oil Charge Amt.
093000000	930	3/8" SAE	3-1/8" ODS 79.38 mm	35-3/4" 908 mm	41-3/8" 1050 mm	13-3/4" 349 mm	12-3/4" 324 mm	11" 279 mm	85 oz. 2.5 Liters
093001000	930R	3/8" SAE	3-1/8" ODS 79.38 mm	37-1/8" 943 mm	42-3/4" 1085 mm	15-1/8" 384 mm	12-3/4" 324 mm	11" 279 mm	5.7 Gal. 21.25 Liters

SELECT OIL SEPARATOR WITH CONNECTION SIZE NOT LESS THAN DISCHARGE LINE SIZE.

NOTE: All separators can be purchased with a Clean-Up® Filter installed by adding CNF to the end of the part number.

When ordering with the Clean-Up® Filter installed you do not get a spare filter. Call for pricing and lead times.

300/900/920/920R Series Notes

For applications other than reciprocating and scroll compressors, (screw type, two-stage) please contact Temprite engineering.

920/920R Series Notes

1. Suitable for all refrigerants including Ammonia and CO₂
2. All products rated for subcritical CO₂ applications and R-410A applications (Max 650 PSIG)

Temprite Standard & Clean-Up® Filters



The Temprite Standard Filter employs a matrix-type borosilicate coalescent filter. These exceptionally pure, extremely fine glass fibers cause the oil molecules to collide, creating bigger droplets, until each is large enough to be forced to the outer drain layer of the filter. The droplets fall to the bottom of the separator and the oil is returned to the compressor. Because the Temprite Standard Filter is finer than any other filter/dryer, it picks up all effluent and dirt in the system down to 0.3 microns in size.

Temprite's Clean-Up® Filters are made of pleated fiber paper that is best suited for cleaning up a very dirty system. After a burnout, just install a Clean-Up® Filter to purge the system of contaminants and you can return the oil to near-virgin state.

Temprite® Conventional Oil Separators

500 & 600 Series

Maximum Working Pressure: 44.8 bar (650 PSI)

The Temprite 500 & 600 Series Conventional Oil Separators are impingement screen separators. In these units, the compressed mass flow enters a larger separator chamber, lowering the velocity of the mass. The atomized oil droplets collect on the impingement screen surface, and as the oil drops become larger they fall to the bottom of the separator oil reservoir.

500 Series Conventional Oil Separators: Accessible Impingement

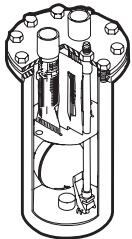

- The 500 Series is designed for the OEM who needs oil separation and accessibility to the unit for filter changes.



Models 501, 502, 503, 504, 505

Part #	Model #	Oil Conn. Size	A Dim.	B Dim.	C Dim.	D Dim.	E Dim.	Oil Charge Amt.
050100000	501	1/4" SAE	1/2" ODS 12.70 mm	10-1/4" 260 mm	3/4" 19 mm	4" 102 mm	5-1/2" 140 mm	16 oz. 475 ml.
050200000	502	1/4" SAE	5/8" ODS 15.88 mm	12-7/8" 327 mm	3/4" 19 mm	4" 102 mm	5-1/2" 140 mm	16 oz. 475 ml.
050300000	503	1/4" SAE	7/8" ODS 22.23 mm	14-5/8" 371 mm	3/4" 19 mm	4" 102 mm	5-1/2" 140 mm	16 oz. 475 ml.
050400000	504	1/4" SAE	1-1/8" ODS 28.58 mm	15-1/2" 394 mm	3/4" 19 mm	4" 102 mm	5-1/2" 140 mm	16 oz. 475 ml.
050500000	505	1/4" SAE	1-3/8" ODS 34.93 mm	18-7/8" 479 mm	3/4" 19 mm	4" 102 mm	5-1/2" 140 mm	16 oz. 475 ml.

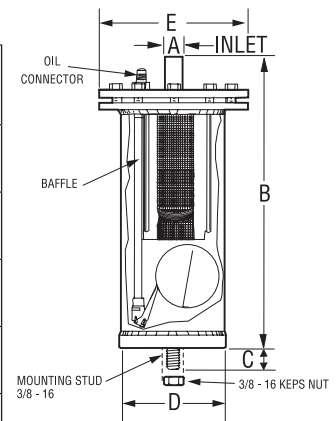

500, 501, 502, 503, 504, 505

Models 506, 507

Part #	Model #	Oil Conn. Size	A Dim.	B Dim.	C Dim.	D Dim.	Oil Charge Amt.
050600000	506*	3/8" SAE	1-5/8" ODS 41.28 mm	15-1/4" 387 mm	20-1/4" 514 mm	6" 152 mm	20 oz. 590 ml.
050700000	507*	3/8" SAE	2-1/8" ODS 53.98 mm	16-1/4" 413 mm	21-1/4" 540 mm	6" 152 mm	20 oz. 590 ml.

* Compatible with NH₃

SELECT OIL SEPARATOR WITH CONNECTION SIZE NOT LESS THAN DISCHARGE LINE SIZE.

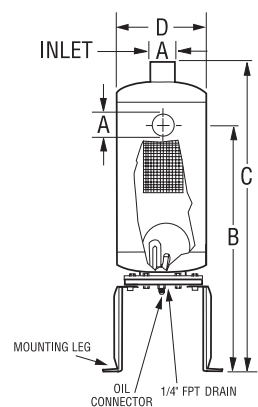

506, 507

600 Series: Hermetic

Maximum Working Pressure: 44.8 bar (650 PSI)

600 Series Conventional Oil Separators: Hermetic Impingement

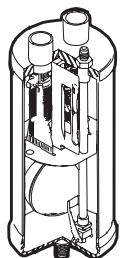

- The 600 Series is designed for the OEM who needs oil separation but does not require the accessibility of the 500 Series.



Models 600, 601, 602, 603, 604, 605

Part #	Model #	Oil Conn. Size	A Dim.	B Dim.	C Dim.	D Dim.	Oil Charge Amt.
060000000	600	1/4" SAE	3/8" ODS 9.53 mm	8-1/8" 206 mm	3/4" 19 mm	4" 102 mm	12 oz. 355 ml.
060100000	601	1/4" SAE	1/2" ODS 12.70 mm	10-1/4" 260 mm	3/4" 19 mm	4" 102 mm	12 oz. 355 ml.
060200000	602	1/4" SAE	5/8" ODS 15.88 mm	12-7/8" 327 mm	3/4" 19 mm	4" 102 mm	12 oz. 355 ml.
060300000	603	1/4" SAE	7/8" ODS 22.23 mm	14-5/8" 371 mm	3/4" 19 mm	4" 102 mm	12 oz. 355 ml.
060400000	604	1/4" SAE	1-1/8" ODS 28.58 mm	15-1/2" 394 mm	3/4" 19 mm	4" 102 mm	12 oz. 355 ml.
060500000	605	1/4" SAE	1-3/8" ODS 34.93 mm	18-7/8" 479 mm	3/4" 19 mm	4" 102 mm	12 oz. 355 ml.

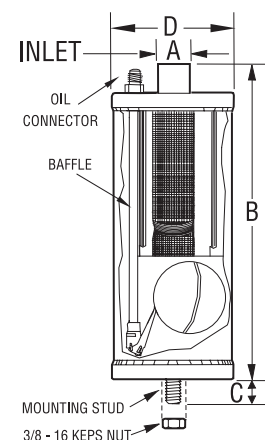

600, 601, 602, 603, 604, 605

Models 606, 607

Part #	Model #	Oil Conn. Size	A Dim.	B Dim.	C Dim.	D Dim.	E Dim.	Oil Charge Amt.
060600000	606*	1/4" SAE	1-5/8" ODS 41.28 mm	13-1/2" 343 mm	18-3/8" 467 mm	6" 152 mm	3" 76 mm	29 oz. 850 ml.
060700000	607*	1/4" SAE	2-1/8" ODS 53.98 mm	14-1/2" 368 mm	19-3/8" 492 mm	6" 152 mm	3" 76 mm	29 oz. 850 ml.

* Compatible with NH₃

SELECT OIL SEPARATOR WITH CONNECTION SIZE NOT LESS THAN DISCHARGE LINE SIZE.

- Gas inlet and outlet connections are female solder bosses to receive O.D. tube size.
- 600 through 607 Series separators are all welded construction with no access to internal components.

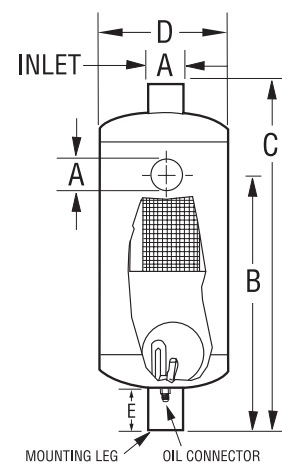

606, 607

Temprite 920 & 920R Series: Capacities in Tons

	Model	922	923	924	925	926	927	928	930
	Connection Size	922R	923R	924R	925R	926R	927R	928R	930R
Refrigerant	Temp °F	Tons @ 100°F Condensing 10° Superheat 0 Subcooling							
R-134a R-1234yf* R-1234ze* R-401A* R-422B* R-422D* R-438A*	+40	5.7	7.9	14.2	22.6	37.0	50.5	84.4	143.4
	+30	4.6	6.4	11.5	18.3	30.0	40.8	68.2	116.0
	+20	3.7	5.1	9.2	14.7	24.0	32.7	54.6	92.8
	+10	2.9	4.1	7.3	11.6	19.0	25.9	43.3	73.6
	0	2.3	3.2	5.7	9.1	14.9	20.4	34.0	57.9
	-10	1.8	2.5	4.4	7.1	11.6	15.8	26.3	44.8
	-20	1.5	2.0	3.6	5.5	9.5	12.9	21.6	36.7
	-30	1.1	1.5	2.7	4.2	7.1	9.7	16.3	27.6
	-40	0.8	1.1	2.0	3.1	5.3	7.3	12.1	20.6
R-22 R-427A*	+40	8.8	12.3	22.1	33.6	57.6	78.5	131.1	222.8
	+30	7.3	10.2	18.4	27.9	47.8	65.2	108.9	185.1
	+20	6.0	8.4	15.1	23.0	39.4	53.7	89.7	152.6
	+10	4.9	6.9	12.4	18.8	32.2	43.9	73.3	124.7
	0	4.0	5.6	10.0	15.3	26.1	35.6	59.5	101.1
	-10	3.2	4.5	8.1	12.2	21.0	28.6	47.8	81.2
	-20	2.6	3.6	6.4	9.7	16.7	22.7	38.0	64.6
	-30	2.0	2.8	5.0	7.7	13.1	17.9	29.8	50.7
	-40	1.6	2.2	3.9	6.0	10.2	13.9	23.2	39.5
R-404A R-407F* R-421A* R-422A* R-422C* R-427A*	+40	9.0	12.5	22.6	34.3	58.7	80.0	133.7	227.3
	+30	7.5	10.4	18.8	28.6	48.9	66.6	111.3	189.3
	+20	6.0	8.3	15.0	22.8	39.1	53.2	89.0	151.2
	+10	4.8	6.7	12.1	18.4	31.5	42.9	71.7	121.9
	0	3.9	5.4	9.7	14.7	25.2	34.3	57.3	97.4
	-10	3.1	4.2	7.6	11.6	19.9	27.1	45.3	77.0
	-20	2.4	3.3	6.0	9.1	15.6	21.2	35.5	60.3
	-30	1.8	2.6	4.6	7.0	12.0	16.4	27.4	46.6
	-40	1.4	2.0	3.5	5.4	9.2	12.5	21.0	35.6
R-410A AZ-20	+40	12.8	17.9	32.1	48.9	83.6	114.0	190.5	323.8
	+30	10.6	14.8	26.6	40.5	69.3	94.5	157.9	268.4
	+20	8.8	12.2	22.0	33.4	57.1	77.9	130.1	221.2
	+10	7.2	10.0	17.9	27.3	46.7	63.7	106.4	180.8
	0	5.8	8.1	14.5	22.1	37.8	51.6	86.2	146.5
	-10	4.7	6.5	11.7	17.8	30.4	41.5	69.3	117.8
	-20	3.7	5.2	9.3	14.1	24.2	33.0	55.1	93.7
	-30	2.9	4.1	7.3	11.1	19.0	26.0	43.4	73.7
	-40	2.3	3.2	5.7	8.7	14.8	20.2	33.8	57.4
R-507 R-402A* R-407A* R-407C*	+40	9.2	12.8	23.1	35.2	60.2	82.0	137.1	233.0
	+30	7.6	10.5	18.9	28.8	49.3	67.2	112.3	190.9
	+20	6.2	8.6	15.4	23.4	40.1	54.6	91.3	155.2
	+10	5.0	6.9	12.4	18.9	32.4	44.1	73.7	125.4
	0	4.0	5.5	9.9	15.1	25.9	35.3	59.0	100.2
	-10	3.1	4.4	7.9	12.0	20.5	28.0	46.7	79.4
	-20	2.5	3.4	6.2	9.4	16.1	21.9	36.6	62.3
	-30	1.9	2.7	4.8	7.3	12.5	17.0	28.4	48.3
	-40	1.5	2.0	3.7	5.6	9.5	13.0	21.7	36.9

* Approximate tonnage, see website for actual tonnage and other refrigerants not listed.

SELECT OIL SEPARATOR WITH CONNECTION SIZE NO LESS THAN DISCHARGE LINE SIZE.

920/920R Series Notes:

1. Suitable for all refrigerants including Ammonia (NH₃, R717) and Carbon Dioxide (CO₂, R744)
2. All products rated for subcritical CO₂ applications and R-410A application (maximum 650 PSI)
3. Tons = Capacity in evaporator (12,000 BTUH/Hr/Ton) based on +100°F Condensing Temperature, +10°F Superheat, 0°F Subcooling.
4. For applications other than reciprocating, screws or 2-stage compressors, please contact Temprite engineering at temprite@temprite.com.

For subcritical CO₂ applications, see page 21.

For Ammonia (NH₃), see page 18.

Temprite 920 & 920R Series: Capacities in kW

	Model	922 922R	923 923R	924 924R	925 925R	926 926R	927 927R	928 928R	930 930R
	Connection Size	5/8"	7/8"	1-1/8"	1-3/8"	1-5/8"	2-1/8"	2-5/8"	3-1/8"
Refrigerant	Temp °C	kW @ 37.8°C Condensing 5.6° superheat 0 subcooling							
R-134a R-1234yf* R-1234ze* R-401A* R-422B* R-422D* R-438A*	4.4	20.0	27.8	50.0	79.6	130.3	177.6	296.7	504.3
	-1.1	16.2	22.5	40.5	64.4	105.4	143.6	240.0	408.0
	-6.7	12.9	18.0	32.4	51.5	84.3	114.9	192.0	326.4
	-12.2	10.3	14.3	25.7	40.9	66.8	91.1	152.2	258.7
	-17.8	8.1	11.2	20.2	32.1	52.6	71.7	119.8	203.6
	-23.3	6.2	8.7	15.6	24.9	40.7	55.4	92.6	157.4
	-28.9	5.1	7.1	12.8	19.5	33.3	45.5	75.9	129.1
	-34.4	3.9	5.4	9.6	14.7	25.1	34.2	57.2	97.2
	-40	2.9	4.0	7.2	10.9	18.7	25.5	42.7	72.5
R-22 R-427A*	4.4	31.1	43.2	77.8	118.3	202.4	275.9	461.0	783.7
	-1.1	25.8	35.9	64.6	98.3	168.2	229.2	383.0	651.2
	-6.7	21.3	29.6	53.2	81.0	138.6	188.9	315.6	536.6
	-12.2	17.4	24.2	43.5	66.2	113.2	154.4	257.9	438.5
	-17.8	14.1	19.6	35.3	53.6	91.8	125.2	209.1	355.5
	-23.3	11.3	15.7	28.3	43.1	73.7	100.5	167.9	285.5
	-28.9	9.0	12.5	22.5	34.3	58.7	80.0	133.6	227.1
	-34.4	7.1	9.8	17.7	26.9	46.1	62.8	104.9	178.3
	-40	5.5	7.7	13.8	21.0	35.9	48.9	81.7	139.0
R-404A R-407F* R-421A* R-422A* R-422C* R-427A*	4.4	31.7	44.1	79.3	120.6	206.5	281.5	470.3	799.6
	-1.1	26.4	36.7	66.1	100.4	171.9	234.4	391.6	665.7
	-6.7	21.1	29.3	52.8	80.3	137.4	187.3	312.9	531.9
	-12.2	17.0	23.6	42.5	64.7	110.7	150.9	252.2	428.7
	-17.8	13.6	18.9	34.0	51.7	88.5	120.6	201.5	342.5
	-23.3	10.7	14.9	26.9	40.9	70.0	95.4	159.4	270.9
	-28.9	8.4	11.7	21.1	32.0	54.8	74.7	124.8	212.1
	-34.4	6.5	9.0	16.3	24.8	42.4	57.7	96.5	164.0
	-40	5.0	6.9	12.4	18.9	32.4	44.1	73.7	125.3
R-410A AZ-20	4.4	45.1	62.8	113.0	171.8	294.1	400.9	669.9	1138.8
	-1.1	37.4	52.1	93.7	142.4	243.8	332.4	555.3	944.0
	-6.7	30.8	42.9	77.2	117.4	200.9	273.9	457.7	778.0
	-12.2	25.2	35.1	63.1	96.0	164.3	223.9	374.1	636.0
	-17.8	20.4	28.4	51.1	77.8	133.1	181.4	303.2	515.4
	-23.3	16.4	22.8	41.1	62.5	107.0	145.9	243.7	414.3
	-28.9	13.1	18.2	32.7	49.7	85.1	116.1	193.9	329.7
	-34.4	10.3	14.3	25.7	39.1	67.0	91.3	152.6	259.3
	-40	8.0	11.1	20.0	30.5	52.2	71.1	118.8	202.0
R-507 R-402A* R-407A* R-407C*	4.4	32.5	45.2	81.3	123.6	211.6	288.5	482.0	819.4
	-1.1	26.6	37.0	66.6	101.3	173.4	236.4	394.9	671.4
	-6.7	21.6	30.1	54.2	82.4	141.0	192.2	321.1	545.8
	-12.2	17.5	24.3	43.8	66.5	113.9	155.2	259.4	440.9
	-17.8	14.0	19.4	35.0	53.2	91.1	124.1	207.4	352.5
	-23.3	11.1	15.4	27.7	42.1	72.1	98.3	164.3	279.3
	-28.9	8.7	12.1	21.7	33.0	56.6	77.1	128.8	219.0
	-34.4	6.7	9.4	16.9	25.7	43.9	59.8	100.0	170.0
	-40	5.1	7.2	12.9	19.6	33.5	45.7	76.3	129.7

* Approximate tonnage, see website for actual tonnage and other refrigerants not listed.

SELECT OIL SEPARATOR WITH CONNECTION SIZE NO LESS THAN DISCHARGE LINE SIZE.

920/920R Series Notes:

1. kW = Capacity based on +37.8°C Condensing temperature, +5.6°C Superheat, 0°C Subcooling
2. Suitable for all refrigerants including Ammonia (NH₃, R717) and Carbon Dioxide (CO₂, R744)
3. For applications other than reciprocating, screws or 2-stage compressors, please contact Temprite engineering at temprite@temprite.com.

For subcritical CO₂ applications, see page 21.

For Ammonia (NH₃), see page 18.

Temprite 920 & 920R Series: Natural Refrigerants, Tons and kW

	Model	922	923	924	925	926	927	928	930
	Connection Size	922R	923R	924R	925R	926R	927R	928R	930R
Refrigerant	Temp °F	Tons @ 100°F Condensing 10° Superheat 0 Subcooling							
R-717 NH ₃	+40	9.9	13.7	24.7	37.5	64.2	87.5	146.2	248.5
	+30	8.1	11.2	20.2	30.7	52.5	71.6	119.7	203.4
	+20	6.5	9.1	16.4	24.9	42.6	58.1	97.1	165.1
	+10	5.3	7.3	13.2	20.0	34.3	46.7	78.1	132.7
	0	4.2	5.8	10.5	15.9	27.3	37.2	62.1	105.6
	-10	3.3	4.6	8.2	12.5	21.4	29.2	48.9	83.0
	-20	2.6	3.6	6.4	9.7	16.7	22.7	38.0	64.6
	-30	2.1	2.9	5.3	8.0	13.7	18.7	31.2	53.1
	-40	1.5	2.1	3.7	5.7	9.7	13.2	22.0	37.5
	Model	922	923	924	925	926	927	928	930
	Connection Size	922R	923R	924R	925R	926R	927R	928R	930R
Refrigerant	Temp °F	Tons @ 25°F Condensing 10° Superheat 0 Subcooling							
R-744 CO ₂ Subcritical (650 PSI max)	+40	29.43	40.93	73.66	112.00	191.70	261.31	436.61	742.23
	+30	25.17	35.01	63.01	95.81	163.99	223.54	373.51	634.96
	+20	21.41	29.78	53.59	81.48	139.46	190.10	317.64	539.98
	+10	18.13	25.22	45.38	69.00	118.11	161.00	269.00	457.31
	0	15.27	21.24	38.23	58.13	99.49	135.62	226.60	385.22
	-10	12.79	17.78	32.00	48.66	83.29	113.53	189.69	322.47
	-20	10.63	14.78	26.60	40.45	69.23	94.37	157.68	268.05
	-30	8.77	12.20	21.96	33.39	57.16	77.91	130.18	221.31
	-40	7.17	9.98	17.95	27.30	46.72	63.69	106.41	180.90
	Model	922	923	924	925	926	927	928	930
	Connection Size	922R	923R	924R	925R	926R	927R	928R	930R
Refrigerant	Temp °C	kW @ 37.8°C Condensing 5.6° Superheat 0 Subcooling							
R-717 NH ₃	4.4	34.6	48.2	86.7	131.9	225.7	307.7	514.1	873.9
	-1.1	28.4	39.5	71.0	108.0	184.8	251.9	420.9	715.5
	-6.7	23.0	32.0	57.6	87.6	150.0	204.4	341.5	580.6
	-12.2	18.5	25.7	46.3	70.4	120.5	164.3	274.5	466.7
	-17.8	14.7	20.5	36.8	56.0	95.9	130.7	218.4	371.3
	-23.3	11.6	16.1	29.0	44.1	75.4	102.8	171.8	292.1
	-28.9	9.0	12.5	22.5	34.3	58.6	79.9	133.5	227.0
	-34.4	7.4	10.3	18.5	28.2	48.2	65.7	109.8	186.6
	-40	5.2	7.3	13.1	19.9	34.0	46.4	77.5	131.7
	Model	922	923	924	925	926	927	928	930
	Connection Size	922R	923R	924R	925R	926R	927R	928R	930R
Refrigerant	Temp °C	kW @ -3.88°C Condensing 5.6° Superheat 0 Subcooling							
R-744 CO ₂ Subcritical (650 PSI max)	4.4	103.7	144.2	259.5	394.6	675.4	920.6	1538.2	2614.9
	-1.1	88.5	123.1	221.6	337.0	576.7	786.2	1313.6	2233.1
	-6.7	75.3	104.8	188.6	286.7	490.7	668.9	1117.7	1900.0
	-12.2	63.7	88.6	159.4	242.4	415.0	565.7	945.1	1606.7
	-17.8	53.7	74.7	134.4	204.4	349.9	477.0	796.9	1354.8
	-23.3	45.0	62.5	112.6	171.1	292.9	399.3	667.2	1134.2
	-28.9	37.4	52.0	93.6	142.3	243.5	332.0	554.7	943.0
	-34.4	30.8	42.9	77.2	117.4	200.9	273.9	457.6	777.9
	-40	25.2	35.1	63.1	96.0	164.3	224.0	374.2	636.2

SELECT OIL SEPARATOR WITH CONNECTION SIZE NO LESS THAN DISCHARGE LINE SIZE.

920/920R Series Note:

For applications other than reciprocating, screws or 2-stage compressors, please contact Temprite engineering at temprite@temprite.com.

Temprite 300 and 900 Series: Coalescent Oil Separators

Refrigerant	Model	320**	340**	900**	901**	902**	903**	904**	905**
	Connection Size	3/8"	3/8"	3/8"	1/2"	5/8"	7/8"	1-1/8"	1-3/8"
Temp °F	Tons @ 100°F Condensing 10° Superheat 0 Subcooling								
R-134a R-1234yf* R-1234ze* R-401A* R-422B* R-422D* R-438A*	+40	1.6	3.2	2.1	4.0	5.7	7.9	14.2	22.6
	+30	1.3	2.6	1.7	3.2	4.6	6.4	11.5	18.3
	+20	1.0	2.0	1.4	2.6	3.7	5.1	9.2	14.7
	+10	0.8	1.6	1.1	2.0	2.9	4.1	7.3	11.6
	0	0.6	1.3	0.9	1.6	2.3	3.2	5.7	9.1
	-10	0.5	1.0	0.7	1.2	1.8	2.5	4.4	7.1
	-20	0.4	0.8	0.5	1.0	1.4	1.9	3.4	5.5
	-30	0.3	0.6	0.4	0.7	1.0	1.4	2.6	3.9
	-40	0.2	0.4	0.3	0.5	0.8	1.1	1.9	2.9
R-22 R-427A*	+40	2.5	4.9	3.3	6.1	8.8	12.3	22.1	33.6
	+30	2.0	4.1	2.7	5.1	7.3	10.2	18.4	27.9
	+20	1.7	3.4	2.3	4.2	6.0	8.4	15.1	23.0
	+10	1.4	2.7	1.8	3.4	4.9	6.9	12.4	18.8
	0	1.1	2.2	1.5	2.8	4.0	5.6	10.0	15.3
	-10	0.9	1.8	1.2	2.2	3.2	4.5	8.1	12.2
	-20	0.7	1.4	1.0	1.8	2.6	3.6	6.4	9.7
	-30	0.6	1.1	0.8	1.4	2.0	2.8	5.0	7.7
	-40	0.4	0.9	0.6	1.1	1.6	2.2	3.9	6.0
R-404A R-407F* R-421A* R-422A* R-422C* R-427A*	+40	2.5	5.0	3.4	6.3	9.0	12.5	22.6	34.3
	+30	2.1	4.2	2.8	5.2	7.5	10.4	18.8	28.6
	+20	1.7	3.3	2.2	4.2	6.0	8.3	15.0	22.8
	+10	1.3	2.7	1.8	3.4	4.8	6.7	12.1	18.4
	0	1.1	2.1	1.4	2.7	3.9	5.4	9.7	14.7
	-10	0.8	1.7	1.1	2.1	3.1	4.2	7.6	11.6
	-20	0.7	1.3	0.9	1.7	2.4	3.3	6.0	9.1
	-30	0.5	1.0	0.7	1.3	1.8	2.6	4.6	7.0
	-40	0.4	0.8	0.5	1.0	1.4	2.0	3.5	5.4
R-410A AZ-20	+40	3.6	7.1	4.8	8.9	12.8	17.9	32.1	48.9
	+30	3.0	5.9	4.0	7.4	10.6	14.8	26.6	40.5
	+20	2.4	4.9	3.3	6.1	8.8	12.2	22.0	33.4
	+10	2.0	4.0	2.7	5.0	7.2	10.0	17.9	27.3
	0	1.6	3.2	2.2	4.0	5.8	8.1	14.5	22.1
	-10	1.3	2.6	1.7	3.2	4.7	6.5	11.7	17.8
	-20	1.0	2.1	1.4	2.6	3.7	5.2	9.3	14.1
	-30	0.8	1.6	1.1	2.0	2.9	4.1	7.3	11.1
	-40	0.6	1.3	0.9	1.6	2.3	3.2	5.7	8.7
R-507 R-402A* R-407A* R-407C*	+40	2.6	5.1	3.5	6.4	9.2	12.8	23.1	35.2
	+30	2.1	4.2	2.8	5.3	7.6	10.5	18.9	28.8
	+20	1.7	3.4	2.3	4.3	6.2	8.6	15.4	23.4
	+10	1.4	2.8	1.9	3.5	5.0	6.9	12.4	18.9
	0	1.1	2.2	1.5	2.8	4.0	5.5	9.9	15.1
	-10	0.9	1.8	1.2	2.2	3.1	4.4	7.9	12.0
	-20	0.7	1.4	0.9	1.7	2.5	3.4	6.2	9.4
	-30	0.5	1.1	0.7	1.3	1.9	2.7	4.8	7.3
	-40	0.4	0.8	0.5	1.0	1.5	2.0	3.7	5.6

* Approximate tonnage, see website for actual tonnage and other refrigerants not listed.

**For 300 and 900 Series Ultra Low Temperature Sizing Chart, see website www.temprite.com.

SELECT OIL SEPARATOR WITH CONNECTION SIZE NO LESS THAN DISCHARGE LINE SIZE.

300 and 900 Series Notes:

1. Tons = Capacity in evaporator (12,000 BTUH/Hr/Ton), based on +100°F Condensing Temperature, +10°F Superheat, 0°F Subcooling
2. For applications other than reciprocating, screws or 2-stage compressors, please contact Temprite engineering at temprite@temprite.com.

Temprite 500 and 600 Series: Conventional Oil Separators

	Model	600	501 601	502 602	503 603	504 604	505 605	506 606	507 607
	Connection Size	3/8"	1/2"	5/8"	7/8"	1-1/8"	1-3/8"	1-5/8"	2-1/8"
Refrigerant	Temp °F	Tons @ 100°F Condensing 10° Superheat 0 Subcooling							
R-134a R-1234yf* R-1234ze* R-401A* R-422B* R-422D* R-438A*	+40	1.22	1.83	3.66	5.49	7.32	9.16	13.00	23.00
	+20	1.17	1.75	3.50	5.24	7.00	8.76	12.43	22.00
	+10	1.14	1.71	3.42	5.12	6.84	8.56	12.14	21.50
	0	1.12	1.67	3.34	4.99	6.68	8.35	11.85	21.00
	-10	1.09	1.63	3.26	4.87	6.52	8.15	11.56	20.50
	-20	1.06	1.59	3.18	4.74	6.36	7.95	11.28	20.00
	-30	1.04	1.55	3.10	4.62	6.20	7.75	10.99	19.50
	-40	1.01	1.51	3.02	4.49	6.04	7.55	10.70	19.00
R-22 R-427A*	+40	1.87	2.80	5.60	8.40	11.20	14.00	23.60	40.00
	+20	1.80	2.70	5.39	8.08	10.78	13.47	22.68	38.50
	+10	1.77	2.64	5.29	7.93	10.57	13.22	22.22	37.76
	0	1.73	2.59	5.18	7.77	10.36	12.95	21.75	37.00
	-10	1.69	2.54	5.08	7.61	10.15	12.69	21.29	36.26
	-20	1.66	2.49	4.97	7.46	9.94	12.43	20.82	35.50
	-30	1.62	2.43	4.86	7.30	9.73	12.16	20.37	34.76
	-40	1.59	2.38	4.76	7.14	9.52	11.90	19.90	34.00
R-404A R-407F* R-421A* R-422A* R-422C* R-427A*	+40	1.87	2.80	5.60	8.40	11.20	14.00	23.60	40.00
	+20	1.80	2.70	5.39	8.08	10.78	13.47	22.68	38.50
	+10	1.77	2.64	5.29	7.93	10.57	13.22	22.22	37.76
	0	1.73	2.59	5.18	7.77	10.36	12.95	21.75	37.00
	-10	1.69	2.54	5.08	7.61	10.15	12.69	21.29	36.26
	-20	1.66	2.49	4.97	7.46	9.94	12.43	20.82	35.50
	-30	1.62	2.43	4.86	7.30	9.73	12.16	20.37	34.76
	-40	1.59	2.38	4.76	7.14	9.52	11.90	19.90	34.00
R-410A AZ-20	+40	2.60	4.00	7.70	11.60	15.50	19.30	32.60	55.20
	+20	2.50	3.85	7.42	11.18	14.90	18.58	31.32	53.12
	+10	2.45	3.78	7.29	10.96	14.60	18.22	30.69	52.10
	0	2.40	3.70	7.15	10.75	14.30	17.85	30.05	51.05
	-10	2.35	3.63	7.01	10.54	14.00	17.49	29.42	50.02
	-20	2.30	3.55	6.88	10.33	13.70	17.13	28.77	48.98
	-30	2.25	3.48	6.74	10.11	13.40	16.77	28.14	47.95
	-40	2.20	3.40	6.60	9.90	13.10	16.40	27.50	46.90
R-507 R-402A* R-407A* R-407C*	+40	1.87	2.80	5.60	8.40	11.20	14.00	23.60	40.00
	+20	1.80	2.70	5.39	8.08	10.78	13.47	22.68	38.50
	+10	1.77	2.64	5.29	7.93	10.57	13.22	22.22	37.76
	0	1.73	2.59	5.18	7.77	10.36	12.95	21.75	37.00
	-10	1.69	2.54	5.08	7.61	10.15	12.69	21.29	36.26
	-20	1.66	2.49	4.97	7.46	9.94	12.43	20.82	35.50
	-30	1.62	2.43	4.86	7.30	9.73	12.16	20.37	34.76
	-40	1.59	2.38	4.76	7.14	9.52	11.90	19.90	34.00

* Approximate tonnage, see website for actual tonnage and other refrigerants not listed.

SELECT OIL SEPARATOR WITH CONNECTION SIZE NO LESS THAN DISCHARGE LINE SIZE.

500 and 600 Series Notes:

1. Tons = Capacity in evaporator (12,000 BTUH/Hr/Ton), based on +100°F Condensing Temperature, +10°F Superheat, 0°F Subcooling
2. For applications other than reciprocating, screws or 2-stage compressors, please contact Temprite engineering at temprite@temprite.com.

Temprite 130 Series for Natural Refrigerants: Tons and kW Transcritical and Subcritical CO₂

	Model	131	133A	135A	137A	138A	139A
	Connection Size	1/4" NPT	1/2" NPT	3/4" NPT	1" or 1-1/4" NPT	1-1/2" NPT*	1-1/2" or 2" NPT**
	Temp. °F	Tons @ 85°F Condensing 10° Superheat 0 Subcooling					
R-744 CO ₂ Transcritical	+58	6.83	12.10	45.37	132.09	192.34	240.69
	+50	6.11	10.83	40.61	118.21	172.13	215.62
	+40	5.29	9.37	35.15	102.32	148.99	186.80
	+30	4.55	8.06	30.24	88.03	128.18	160.82
	+23	4.08	7.23	27.11	78.92	114.92	144.22
	+20	3.89	6.89	25.84	75.23	109.54	137.48
	+10	3.30	5.85	21.95	63.89	93.03	116.79
	0	2.79	4.94	18.51	53.88	78.46	98.51
	-10	2.33	4.13	15.49	45.09	65.66	82.43
	-20	1.94	3.43	12.85	37.42	54.49	68.40
	-30	1.59	2.82	10.58	30.81	44.86	56.30
-40	1.30	2.30	8.62	25.09	36.53	45.83	
	Connection Size	1/4" NPT	1/2" NPT	3/4" NPT	1" or 1-1/4" NPT	1-1/2" NPT*	1-1/2" or 2" NPT**
	Temp. °C	kW @ 29.44°C Condensing 5.6° Superheat 0 Subcooling					
R-744 CO ₂ Transcritical	+14.7	24.03	42.56	159.58	464.56	676.45	846.52
	+9.7	21.50	38.08	142.82	415.76	605.39	758.35
	+4.4	18.61	32.96	123.62	359.86	524.00	656.99
	-1.1	16.01	28.36	106.35	309.61	450.83	565.61
	-5	14.36	25.43	95.35	277.57	404.17	507.23
	-6.7	13.68	24.24	90.88	264.57	385.24	483.52
	-12.2	11.62	20.58	77.19	224.70	327.19	410.77
	-17.8	9.80	17.36	65.10	189.51	275.94	346.46
	-23.3	8.20	14.53	54.48	158.58	230.92	289.92
	-28.9	6.81	12.06	45.21	131.61	191.64	240.57
	-34.4	5.60	9.93	37.22	108.36	157.78	198.02
-40	4.56	8.08	30.31	88.23	128.48	161.19	
	Connection Size	1/4" NPT	1/2" NPT	3/4" NPT	1" or 1-1/4" NPT	1-1/2" NPT*	1-1/2" or 2" NPT**
	Temp. °F	Tons @ 25°F Condensing 10° Superheat 0 Subcooling					
R-744 CO ₂ Subcritical	+58	12.44	22.04	82.65	240.61	350.36	455.97
	+50	11.01	19.50	73.14	212.91	310.02	403.47
	+40	9.43	16.71	62.64	182.37	265.54	345.59
	+30	8.05	14.27	53.50	155.75	226.78	295.14
	+23	7.20	12.74	47.79	139.12	202.58	263.64
	+20	6.85	12.13	45.50	132.45	192.86	251.00
	+10	5.80	10.28	38.53	112.17	163.33	212.57
	0	4.89	8.66	32.46	94.49	137.59	179.06
	-10	4.09	7.25	27.17	79.10	115.17	149.89
	-20	3.40	6.02	22.59	65.75	95.74	124.60
	-30	2.81	4.97	18.65	54.28	79.04	102.87
-40	2.29	4.06	15.24	44.37	64.61	84.09	
	Connection Size	1/4" NPT	1/2" NPT	3/4" NPT	1" or 1-1/4" NPT	1-1/2" NPT*	1-1/2" or 2" NPT**
	Temp. °C	kW @ -3.889°C Condensing 5.56° Superheat 0 Subcooling					
R-744 CO ₂ Subcritical	+14.7	43.76	77.52	290.69	846.23	1232.20	1603.64
	+9.7	38.73	68.59	257.22	748.80	1090.33	1419.00
	+4.4	33.17	58.75	220.32	641.38	933.92	1215.44
	-1.1	28.33	50.18	188.16	547.76	797.60	1038.02
	-5	25.31	44.82	168.08	489.29	712.46	927.23
	-6.7	24.09	42.67	160.02	465.82	678.29	882.75
	-12.2	20.40	36.14	135.52	394.50	574.44	747.60
	-17.8	17.19	30.44	114.16	332.32	483.89	629.76
	-23.3	14.39	25.48	95.56	278.19	405.07	527.17
	-28.9	11.96	21.18	79.43	231.24	336.70	438.20
	-34.4	9.87	17.49	65.58	190.91	277.99	361.79
-40	8.07	14.30	53.61	156.06	227.23	295.73	

SELECT OIL SEPARATOR WITH CONNECTION SIZE NO LESS THAN DISCHARGE LINE SIZE.

* Customer specified: Butt Weld or Male Pipe Thread

** Butt Weld only.

See page 18 for the 920 and 920R Series of components, suitable for subcritical applications up to 44.8 bar (650 PSI). The 920 and 920R Series are also ammonia compatible.

130 Series Note:

For applications other than reciprocating, screws or 2-stage compressors, please contact Temprite engineering at temprite@temprite.com.

Quick Reference Chart

Model	Connection Size A	R-134a MP 39		R-22		R-404A HP-62, HP-80		R-410A		R-507		R-717		R-744	
		+40 Tons	-20 Tons	+40 Tons	-40 Tons	+40 Tons	-40 Tons	+40 Tons	-40 Tons	+40 Tons	-40 Tons	+40 Tons	-40 Tons	+40 Tons	-40 Tons
131	1/4"													5.3	1.3
133A	1/2"													9.4	2.3
135A	3/4"													35.1	8.6
137A	1" or 1-1/4"													102.3	25.1
138A	1-1/2"													149.0	36.5
139A	1-1/2" or 2"													186.8	45.8
320*	3/8" ODS	1.6	0.4	2.5	0.4	2.5	0.4	3.6	0.6	2.6	0.4				
321*	1/8" FPT	1.6	0.4	2.5	0.4	2.5	0.4	3.6	1.3	2.6	0.4				
322*	1/4" SAE	1.6	0.4	2.5	0.4	2.5	0.4	3.6	0.6	2.6	0.4				
340*	3/8" ODS	3.2	0.8	4.9	0.9	5.0	0.8	7.1	1.3	5.1	0.8				
341*	1/8" FPT	3.2	0.8	4.9	0.9	5.0	0.8	7.1	1.3	5.1	0.8				
342*	1/4" SAE	3.2	0.8	4.9	0.9	5.0	0.8	7.1	1.3	5.1	0.8				
343*	3/8" SAE	3.2	0.8	4.9	0.9	5.0	0.8	7.1	1.3	5.1	0.8				
900*	3/8" ODS	2.1	0.5	3.3	0.6	3.4	0.5	4.8	0.9	3.5	0.5				
900-1*	3/8" ODS	2.1	0.5	3.3	0.6	3.4	0.5	4.8	0.9	3.5	0.5				
901*	1/2" ODS	4.0	1.0	6.1	1.1	6.3	1.0	8.9	1.6	6.4	1.0				
902*	5/8" ODS	5.7	1.4	8.8	1.6	9.0	1.4	12.8	2.3	9.2	1.5				
903*	7/8" ODS	7.9	1.9	12.3	2.2	12.5	2.0	17.9	3.2	12.8	2.0				
904*	1-1/8" ODS	14.2	3.4	22.1	3.9	22.6	3.5	32.1	5.7	23.1	3.7				
905*	1-3/8" ODS	22.6	5.5	33.6	6.0	34.3	5.4	48.9	8.7	35.2	5.6				
922/R	5/8" ODS	5.7	1.4	8.8	1.6	9.0	1.4	12.8	2.3	9.2	1.5	9.9	1.5	29.4	7.2
923/R	7/8" ODS	7.9	1.9	12.3	2.2	12.5	2.0	17.9	3.2	12.8	2.0	13.7	2.1	40.3	10.0
924/R	1-1/8" ODS	14.2	3.4	22.1	3.9	22.6	3.5	32.1	5.7	23.1	3.7	24.7	3.7	73.7	18.0
925/R	1-3/8" ODS	22.6	5.5	33.6	6.0	34.3	5.4	48.9	8.7	35.2	5.6	37.5	5.7	112.0	27.3
926/R	1-5/8" ODS	37.0	8.9	57.6	10.2	58.7	9.2	83.6	14.8	60.2	9.5	64.2	9.7	191.7	46.7
927/R	2-1/8" ODS	50.5	12.2	78.5	13.9	80.0	12.5	114.0	20.2	82.0	13.0	87.5	13.2	261.3	63.7
928/R	2-5/8" ODS	84.4	20.3	131.1	23.2	133.7	21.0	190.5	33.8	137.1	21.7	146.2	22.0	436.6	106.4
930/R	3-1/8" ODS	143.4	34.6	222.8	39.5	227.3	35.6	323.8	57.4	233.0	36.9	248.5	37.5	742.2	180.9
501	1/2" ODS	1.8	1.6	2.8	2.4	2.8	2.4	4.0	3.4	2.8	2.4				
502	5/8" ODS	3.7	3.2	5.6	4.8	5.6	4.8	7.7	6.6	5.6	4.8				
503	7/8" ODS	5.5	4.7	8.4	7.1	8.4	7.1	11.6	9.9	8.4	7.1				
504	1-1/8" ODS	7.3	6.4	11.2	9.5	11.2	9.5	15.5	13.1	11.2	9.5				
505	1-3/8" ODS	9.2	8.0	14.0	11.9	14.0	11.9	19.3	16.4	14.0	11.9				
506	1-5/8" ODS	13.0	11.3	23.6	19.9	23.6	19.9	32.6	27.5	23.6	19.9	26.7	24.6		
507	2-1/8" ODS	23.0	20.0	40.0	34.0	40.0	34.0	55.2	46.9	40.0	34.0	45.2	41.7		
600	3/8" ODS	1.2	1.1	1.9	1.6	1.9	1.6	2.6	2.2	1.9	1.6				
601	1/2" ODS	1.8	1.6	2.8	2.4	2.8	2.4	4.0	3.4	2.8	2.4				
602	5/8" ODS	3.7	3.2	5.6	4.8	5.6	4.8	7.7	6.6	5.6	4.8				
603	7/8" ODS	5.5	4.7	8.4	7.1	8.4	7.1	11.6	9.9	8.4	7.1				
604	1-1/8" ODS	7.3	6.4	11.2	9.5	11.2	9.5	15.5	13.1	11.2	9.5				
605	1-3/8" ODS	9.2	8.0	14.0	11.9	14.0	11.9	19.3	16.4	14.0	11.9				
606	1-5/8" ODS	13.0	11.3	23.6	19.9	23.6	19.9	32.6	27.5	23.6	19.9	26.7	24.6		
607	2-1/8" ODS	23.0	20.0	40.0	34.0	40.0	34.0	55.2	46.9	40.0	34.0	45.2	41.7		

* For 300 and 900 Series Ultra Low Temperatures Sizing Chart go to www.temprite.com.

SELECT OIL SEPARATOR WITH CONNECTION SIZE NO LESS THAN DISCHARGE LINE SIZE.

Notes:

1. Tons = Capacity in evaporator (12,000 BTUH/Hr/Ton), based on +100°F Condensing Temperature, +10°F Superheat, 0°F Subcooling
2. For applications other than reciprocating, screws or 2-stage compressors, please contact Temprite engineering at temprite@temprite.com.



Photos are not to scale

Oil Level Controls: Mechanical

Maximum Working Pressure: 44.8 bar (650 PSI)

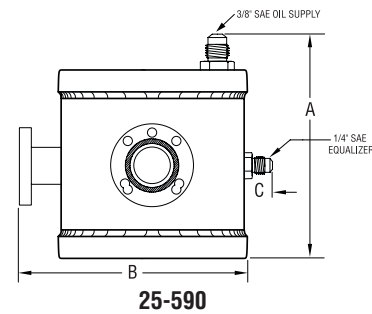
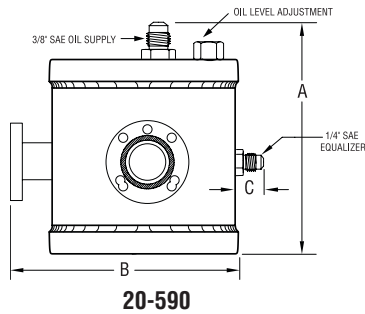

Part #	Model #	Operating Range	A Dim.	B Dim.	C Dim.	Refrigerants
020590000	20-590*	Adjustable 5-90 PSI .35-6.2 bar	5-5/8" 143 mm	5-1/2" 140 mm	3/4" 19 mm	All*
025590000	25-590	Non-adjustable 5-90 PSI .35-6.2 bar	5-3/8" 136 mm	5-3/8" 136 mm	3/4" 19 mm	All*

*Can be manufactured for ammonia (NH₃).

Temprite® Oil Reservoirs

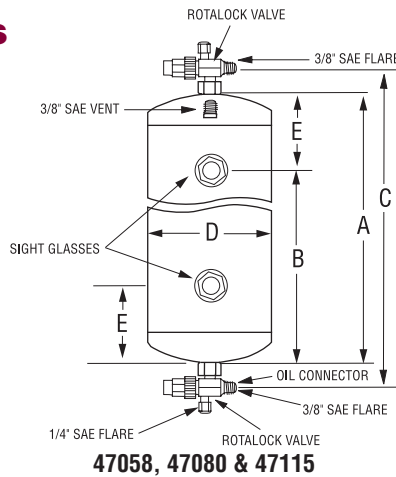

Models 47058, 47080 & 47115

Maximum Working Pressure: 44.8 bar (650 PSI)

Part #	Model #	Oil Conn. Size	A Capacity	B Capacity	A Dim.	B Dim.	C Dim.	D Dim.	E Dim.	Sight Glasses
90010000	47058	3/8" SAE	1.6 Gal. 196 oz. 5.8 Liters	1.2 Gal. 146 oz. 4.318 Liters	13-1/2" 343 mm	9-3/4" 248 mm	16-1/2" 413 mm	6" 152 mm	3-3/4" 95 mm	2
90020000	47080	3/8" SAE	2.1 Gal. 270 oz. 8 Liters	1.7 Gal. 220 oz. 6.506 Liters	19-1/4" 489 mm	15-1/2" 394 mm	22-1/4" 559 mm	6" 152 mm	3-3/4" 95 mm	2
90030000	47115	3/8" SAE	3 Gal. 388 oz. 11.5 Liters	2.6 Gal. 338 oz. 9.996 Liters	27-1/4" 692 mm	23-1/2" 596 mm	30-1/4" 762 mm	6" 152 mm	3-3/4" 95 mm	2

Temprite® Oil Reservoirs

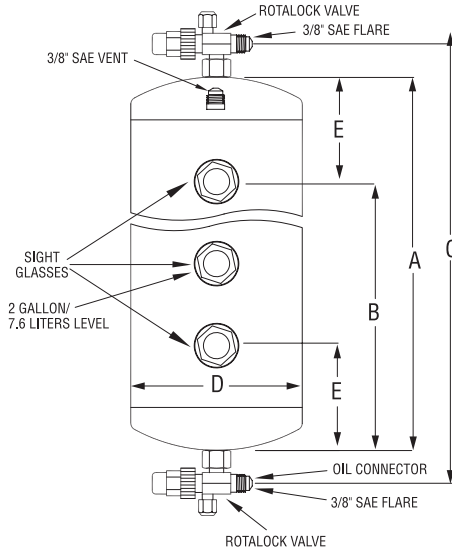

47154

Model 47154

Maximum Working Pressure: 44.8 bar (650 PSI)

Part #	Model #	Oil Conn. Size	A Capacity	B Capacity	A Dim.	B Dim.	C Dim.	D Dim.	E Dim.	Sight Glasses
90040000	47154	3/8" SAE	4 Gal. 512 oz. 15 Liters	3.5 Gal. 448 oz. 13.25 Liters	37" 940 mm	31-7/8" 810 mm	40" 1016 mm	6" 152 mm	5-1/8" 130 mm"	3

RES7 & RES17 Oil Reservoirs

**Maximum Working Pressure:
130 bar (1885 PSI)**

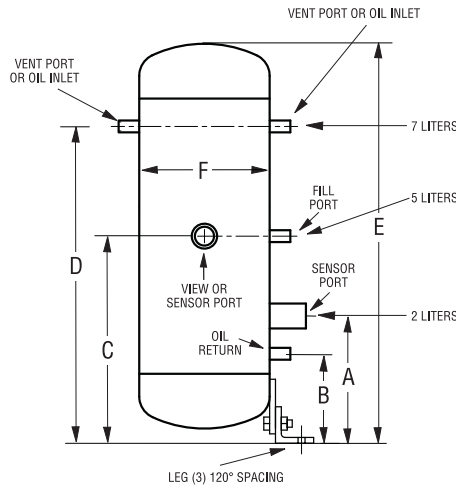

Part #	Model #	Vent Port/ Oil Inlet/Oil Return	View/ Sensor Port Conn.	A Dim.	B Dim.	C Dim.	D Dim.	E Dim.	F Dim.
				Sensor Port	Oil Return	View/ Fill Port	Vent Port/ Oil Inlet	Overall Height	Dia.
013700000	RES7	1/4" FPT**	3/4" FPT**	213 mm 8-3/8" 2 Liters	127 mm 5"	444 mm 17-1/2" 5 Liters	600 mm 23-5/8" 7 Liters	711 mm 28"	141 mm 5-9/16"
013900017	RES17*	1/4" FPT**	3/4" FPT**	289 mm 11-3/8" 7 Liters	152 mm 6"	424 mm 16-11/16" 11 Liters	606 mm 23-7/8" 16.5 Liters	735 mm 29"	213 mm 8-5/8"

* 17-Liter reservoirs and larger installed in Canada must be ASME vessels with a CRN number. Order a model RES17 ASME.

** FPT=Female Pipe Thread, MPT=Male Pipe Thread, BW=Butt Weld

Oil Return Floats

Maximum Working Pressure: 44.8 bar (650 PSI)

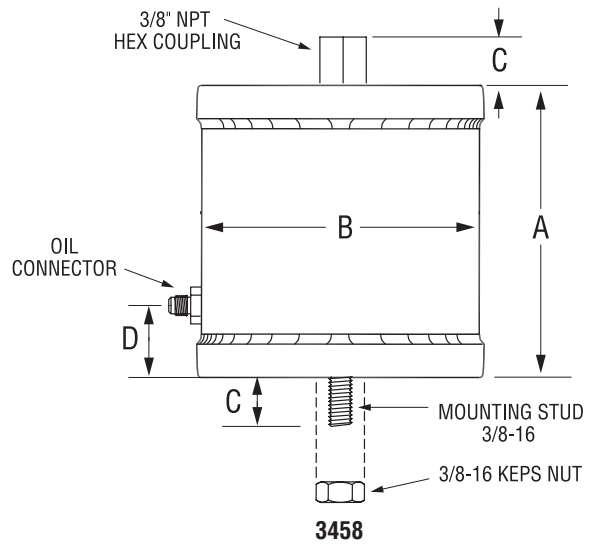
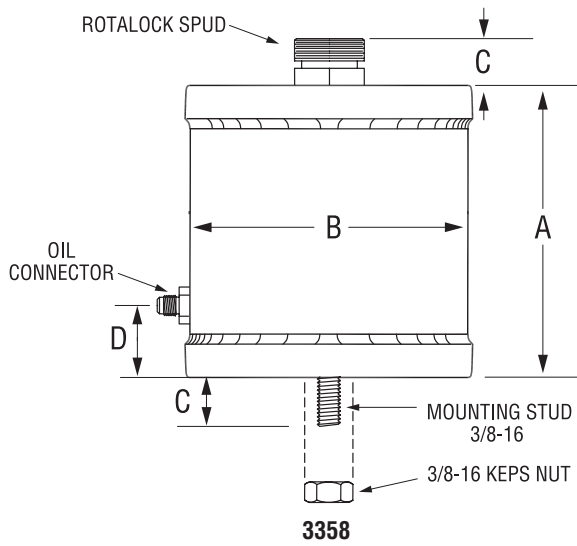

Models 3358, 3458: Hermetic

Part #	Model #	Oil Outlet	Top Connection Size	A Dim.	B Dim.	C Dim.	D Dim.	Refrigerant
003358000	3358	1/4" SAE	3/4-16 Rotalock Spud	4-7/8" 124 mm	4" 102 mm	3/4" 19 mm	1-1/2" 38 mm	All** Specify for Ammonia
003458000	3458	1/4" SAE	3/8" NPT Hex Coupling	4-7/8" 124 mm	4" 102 mm	3/4" 19 mm	1-1/2" 38 mm	All** Specify for Ammonia

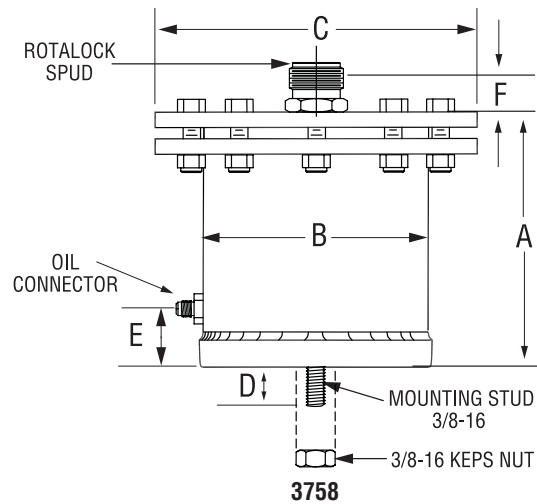
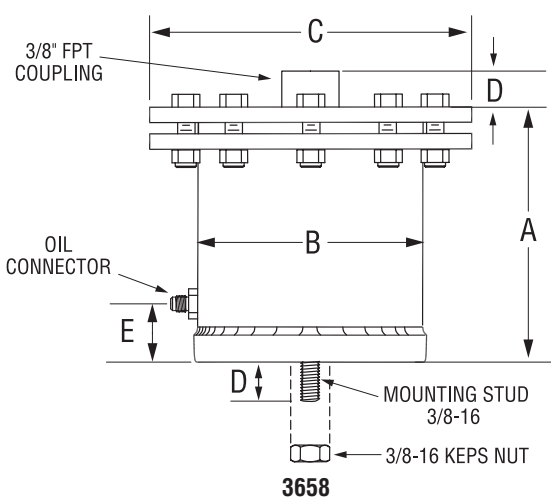

Models 3658, 3758: Accessible

Part #	Model #	Oil Outlet	Top Connection Size	A Dim.	B Dim.	C Dim.	D Dim.	E Dim.	F Dim.	Refrigerant
003658000	3658	1/4" SAE	3/8" FPT* Coupling	4-5/8" 118 mm	4" 102 mm	5-1/2" 140 mm	3/4" 19 mm	1-5/16" 33 mm	N/A	All** Specify for Ammonia
003758000	3758	3/8" SAE	3/4-16 Rotalock Spud	4-5/8" 118 mm	4" 102 mm	5-1/2" 140 mm	3/4" 19 mm	1-5/16" 33 mm	11/16" 17.5 mm	All** Specify for Ammonia

* FPT=Female Pipe Thread, MPT=Male Pipe Thread, BW=Butt Weld

Valves

- Oil moving from the oil separator to the oil reservoir or oil level controls is at a higher discharge pressure. This pressure must be reduced to a pressure slightly higher than the compressor crankcase.
- To maintain proper oil return, each of the oil system components must be selected according to the requirements of the overall oil control system.



High Pressure System: A-7 or Y1236C Valve

- If your system has an oil separator with a built-in oil reservoir, you will need one of two models, depending on your system: either an A-7, a constant-outlet pressure valve, or a Y1236C, a variable-outlet pressure valve.*

*The majority of Temprite 920R Series users monitor the oil back to the oil level control via the A-7 pressure-reducing valve set to the desired pressure.

- The Y1236C is designed for high-pressure oil return systems, or other situations where a differential pressure regulator is required.

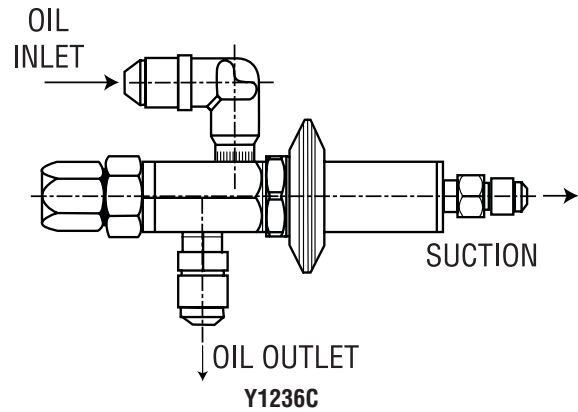
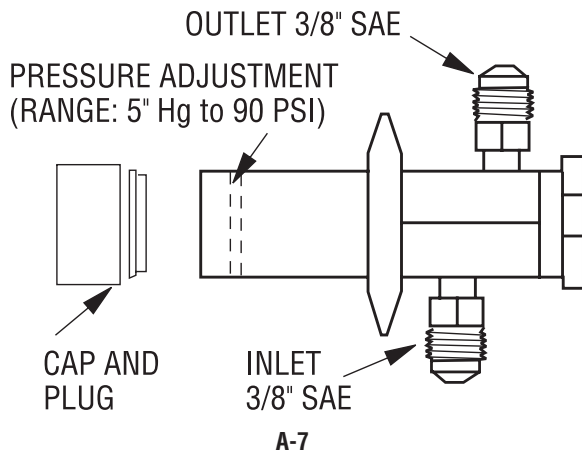

Notes:
 If you are using a split-suction header, i.e., +20°F, -20°F, you will need two (2) A-7 valves or two (2) Y1236 valves, one per suction group.
 A TraxOil electronic oil level control does not require a pressure-reducing valve.

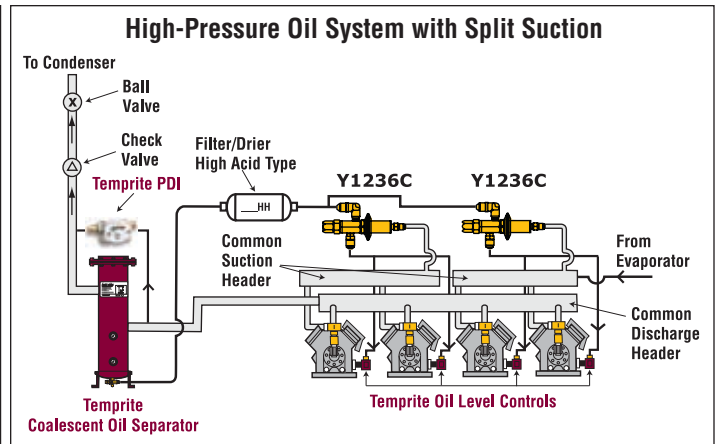
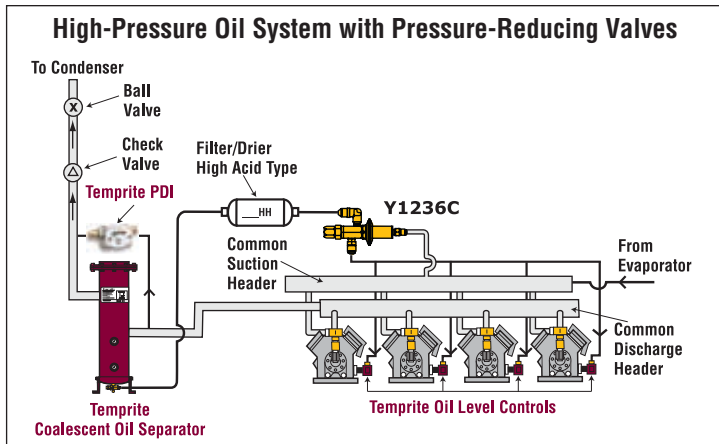

Valves

Low Pressure System: OCV-20 Valve

If your system has an oil separator with an external reservoir, you need the OCV-20. The Oil Differential Check Valve-20 (OCV-20) relieves pressure from the reservoir to the suction header to maintain a higher pressure in the reservoir at a pre-set level above the suction pressure.

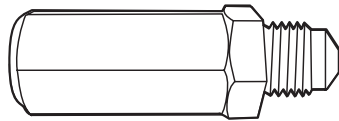

OCV-20

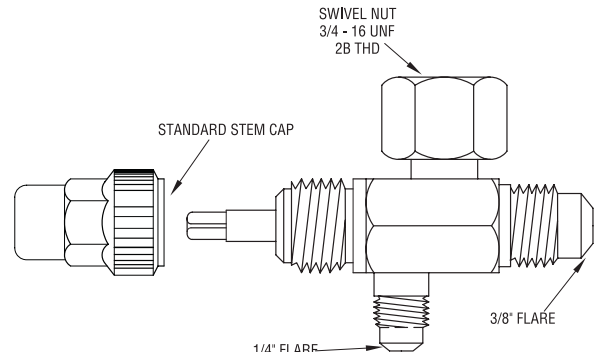

Rotalock Valve

Part #	Model #	Operating Range	Max. Working Press.	Connection Size	Refrigerant
67030000	Rotalock Valve	N/A	650 PSI	3/4" and 3/8" SAE	All*
67050000	A-7	5" Hg-90 PSI	400 PSI	3/8" SAE	All*
67071020	OCV-20	N/A	650 PSI	3/8" SAE	All*
67071236	Y1236C	10 to 25 PSI	650 PSI	3/8" SAE	All*

* Except Ammonia (NH₃)

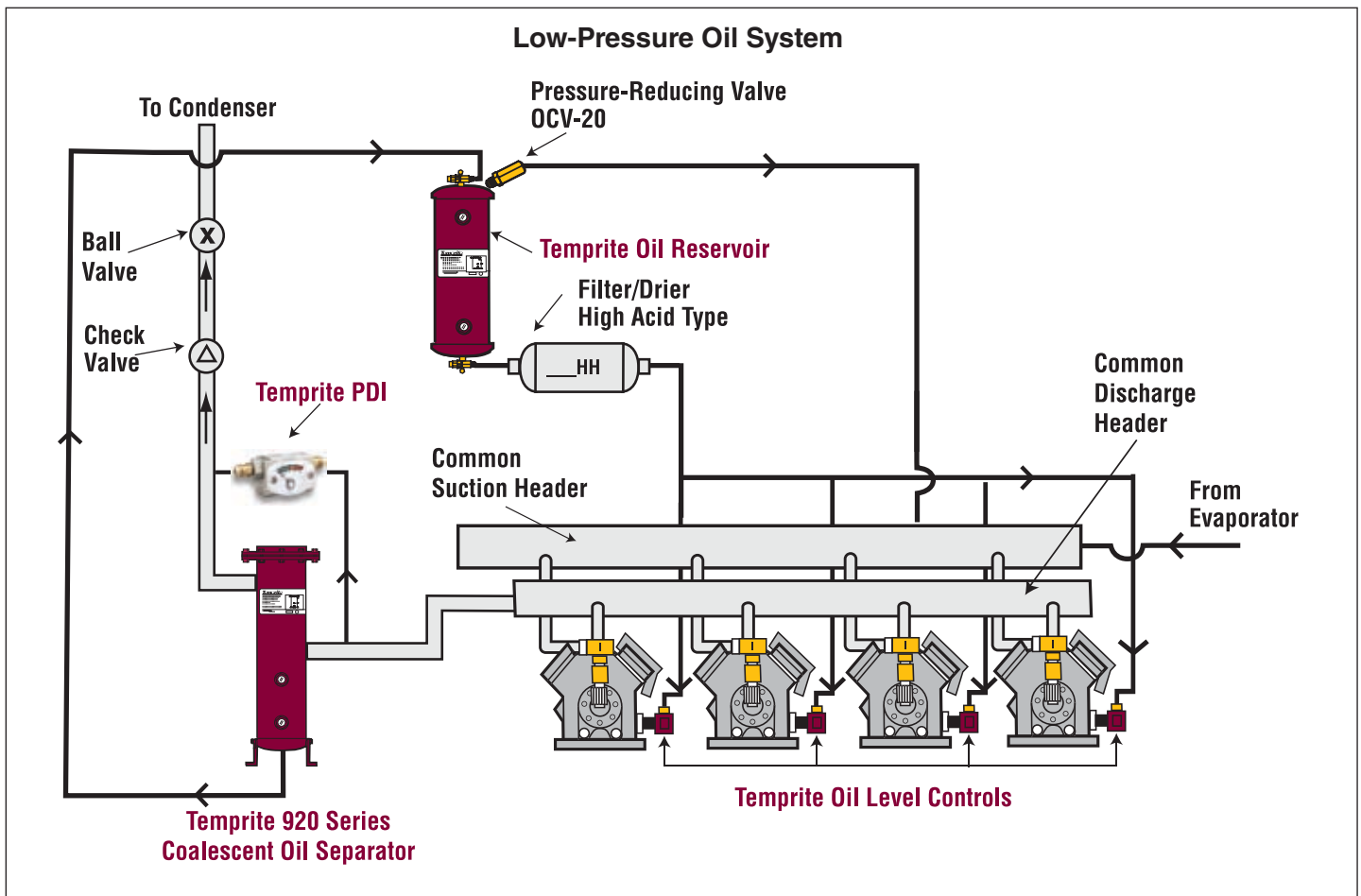

HB Products for CO₂



HBOC



HBSO1



HBPA



V100

HBOC Oil Level Control Sensor & Switch for R744 (CO₂)

Maximum Working Pressure: 150 bar (2175 PSI)

The HBOC Oil Level Control Sensor & Switch is designed to automatically control oil levels in oil separator systems and for compressor protection. The oil carry-over from compressors in multiple compressor parallel rack systems requires proper oil management. The HBOC is designed to control lubrication and prevent compressor breakdown.

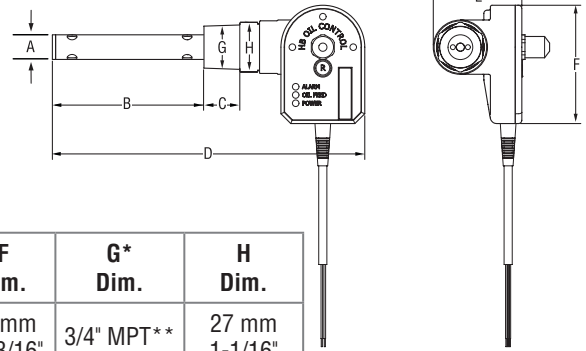

Part #	Model #	A Dia.	B Dim.	C Dim.	D Dim.	E Dim.	F Dim.	G* Dim.	H Dim.
84003034	HBOC	15 mm 19/32"	92 mm 3-5/8"	22 mm 7/8"	190 mm 7-1/2"	54 mm 2-1/8"	72 mm 2-13/16"	3/4" MPT**	27 mm 1-1/16"

HBSO1 Oil Level Sensor for R744 (CO₂)

HBSO1 is an oil level sensor for detecting common lubricating oils in separators and filter systems, for oil management and oil level control, as well as for compressor protection. It serves as an oil level sensor for transcritical CO₂ applications, senses the oil level in compressors and activates alarms. The HBSO1 can be installed in the compressor to secure or control lubrication for both high- and low-pressure applications.

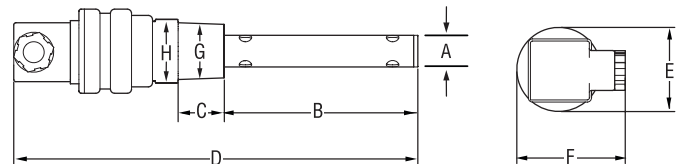

- The HBSO1 can also be installed in the oil separator or reservoir.

Part #	Model #	A Dia.	B Dim.	C Dim.	D Dim.	E Dim.	F Dim.	G Dim.	H Dim.
82006034	HBSO1	15 mm 19/32"	92 mm 3-5/8"	22 mm 7/8"	192 mm 7-9/16"	40 mm 1-5/8"	52 mm 2-1/16"	3/4"* MPT** (24VDC)	27 mm 1-1/16"

*Thread connection size: 3/4". Contact temprite@temprite.com about availability and lead time for the 1/2" and 1-1/8" threads.

** FPT=Female Pipe Thread, MPT=Male Pipe Thread

HB Products for CO₂ **HB** Products

The schematic below shows the HBOC oil level control sensor & switch and the HBSO1 oil level sensor on a system.

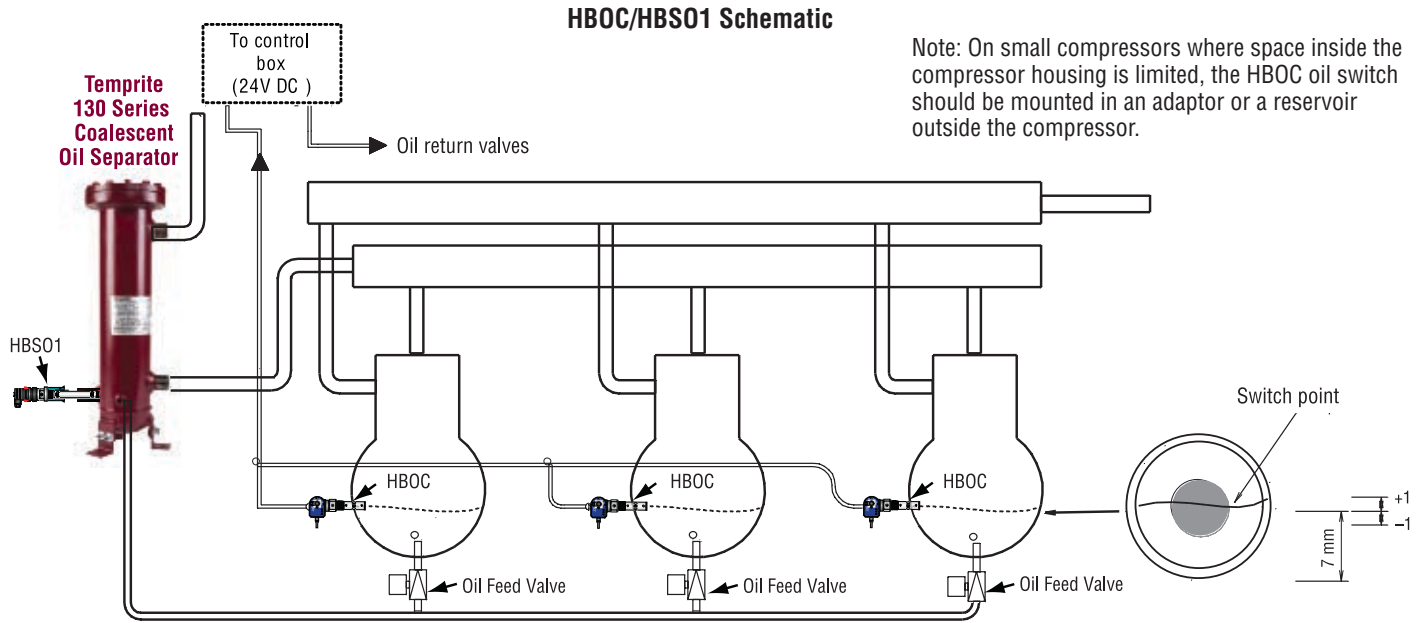

HBPA Voltage Converter for HBSO1

The HBPA Voltage Converter is for use with the HBSO1 Sensor. It converts 90/240VAC to 24VDC where the standard plug must be changed with a power adaptor.

The HBPA has a built-in transistor output, making it possible to control solenoid valves directly with a max consumption of 40W.

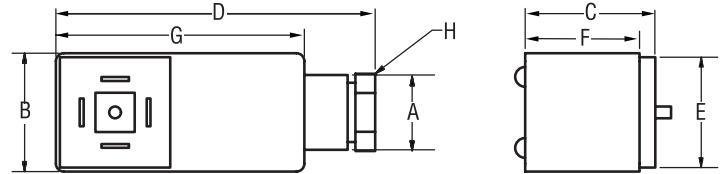

Part #	Model #	Cable Length	A Dim.	B Dim.	C Dim.	D Dim.	E Dim.	F Dim.	G Dim.	H Dim.
84002099	HBPA	3 m 9' 10"	19 mm 3/4"	30 mm 1-3/16"	33 mm 1-5/16"	81 mm 3-3/16"	28 mm 1-3/32"	29 mm 1-1/8"	64 mm 2-1/2"	17 mm 11/16"

V100 Solenoid Valve

Maximum Working Pressure: 100 bar

The V100 Solenoid Valve connects to the HBOC in compressor and oil separator installations. The solenoid valve is controlled directly by the HBOC.

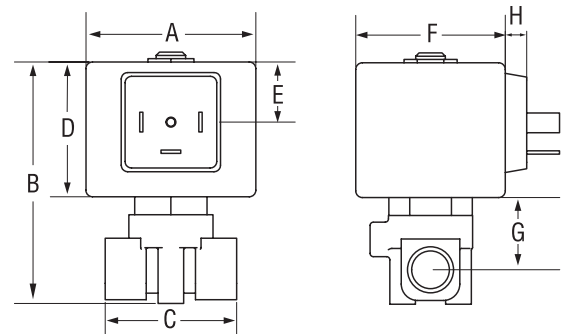

Part #	Model #	Oil Conn. Size	A Dim.	B Dim.	C Dim.	D Dim.	E Dim.	F Dim.	G Dim.	H Dim.
84003100	V100	1/4" FPT*	52 mm 2-1/16"	74 mm 2-15/16"	40 mm 1-9/16"	41 mm 1-5/8"	18 mm 3/4"	46 mm 1-13/16"	22 mm 7/8"	7 mm 1/4"

* FPT=Female Pipe Thread, MPT=Male Pipe Thread

TraxOil Electronic Oil Level Controls



TraxOil products are approved by the major compressor manufacturers

The new* TR3 TraxOil Level Control system accurately detects and controls oil levels in commercial HVAC oil-refrigeration compressors. TraxOil electronic oil level controls (OLCs) are compressor mounted. The TR3's lightweight aluminum base and state-of-the-art design and engineering make it perfect for use with scroll and reciprocating refrigeration compressors.

*The TR3 Series replaces the TOUS Series. TOUS adaptor plates are not interchangeable.

NOTE: An A-7 or Y1236C valve is not required with a TraxOil Electronic OLC.

Key Features

- Digital processor with SMT components
- Alarm relay can switch 24 to 240 VAC
- CE approved, EMC emissions and immunity
- UL approved
- Meets European RoHS and WEEE directives
- All timing functions are in true time
- IP65 rated for dust and water
- Waterproof cables with no wiring at TraxOil unit
- No orifice restrictor
- Danfoss coil and enclosing tube complete with internal solenoid seat
- Tamperproof, cannot be adjusted in field
- Set point levels use true levels with no timing overruns
- Easily removable inlet fitting with built-in filter screen

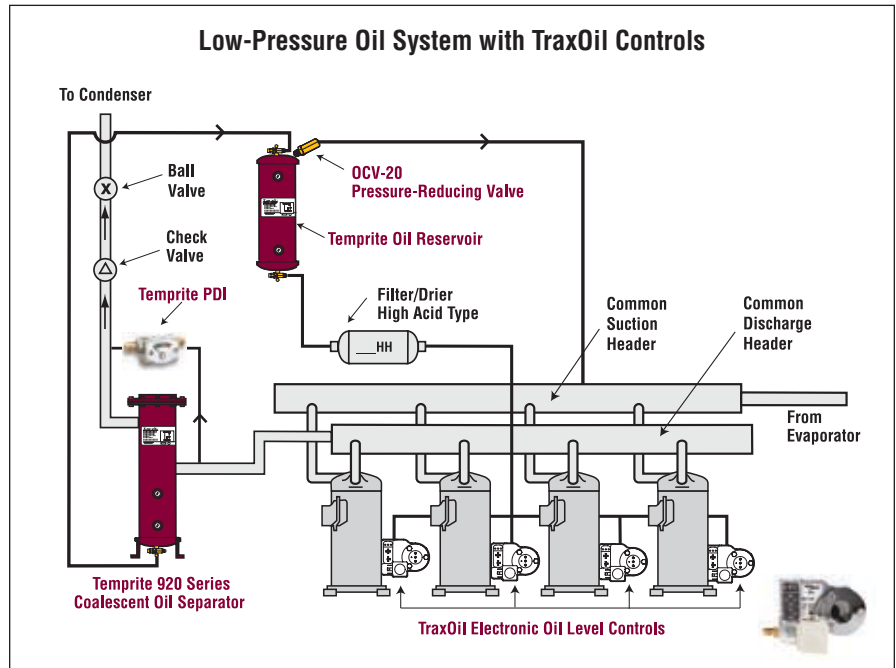
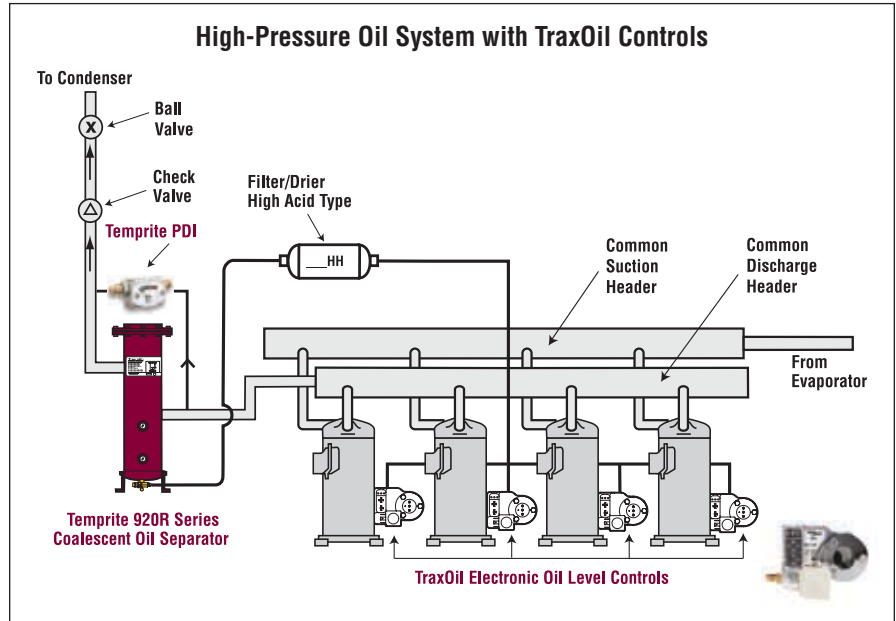

TraxOil Electronic Oil Level Controls

Operation

The TR3 electronic oil level control is mounted in place of the oil level sight glass at the compressor's crankcase. A mechanical level detector (float and Hall sensor) monitors the oil level and transmits information to the control logic.

The integrated solenoid valve feeds oil directly into the compressor sump when the compressor oil level is low. If the correct oil level cannot be reached and goes into the red zone (see diagram below) the TR3 emits an alarm signal. The alarm contacts can be used to shut down or isolate the compressor.

The sight glass is divided into three main zones. When the level reaches the yellow zone (2) the TR3 starts filling after a time delay of 10 seconds. When the level drops to the red zone (3) the control will switch the alarm relay contacts on after a time delay of 20 seconds. The current oil status is indicated with the three (3) LEDs according to the following table:

LED	Status / Function
● Green	Oil Level zone 1 (50 – 40%)
● Yellow	Oil Level zone 2 (40 – 30%) injection
● Red ● Yellow	Oil Level zone 3 (30 – 0%) alarm & injection

Oil level zones
Specially Low
Calibrated units

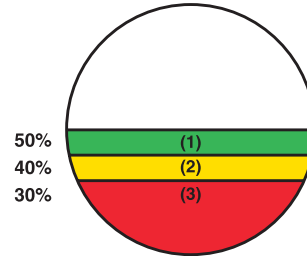

Technical Data

Max working pressure	43 bar	Time delay filling (Yellow)	10 sec
Solenoid MOPD	21 bar	Time delay alarm (Red)	20 sec
Current	0.7 A	Medium temperature	-20→80°C
Supply voltage (to be fused with 5Amp fuse)	24V AC only, 50/60Hz +10/-15%	Medium Compatibility (<i>not released for flammable refrigerants or ammonia</i>)	HFC, HCFC, CO ₂
Solenoid Coil	24VAC 50/60 Hz	Storage and transport temp	-20→50°C
Alarm contact rating	Max 3A 240 VAC	Ambient temp (Housing)	-20→50°C
Alarm switch	SPDT	Protection class (DIN43650)	IP65

TraxOil Electronic Oil Level Controls

Maximum Working Pressure: 43 bar (634 PSI)

Part Number	Model
83003201	TR3201
83003202	TR3202
83003203	TR3203
83003204	TR3204
83003210	TR3210

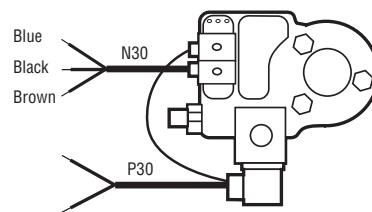

Model TR3201

TraxOil OilWatches

Maximum Working Pressure: 43 bar (634 PSI)

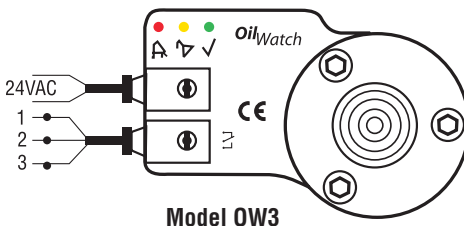

Model OW3

The OW3 OilWatch system is a self-contained system that provides oil level monitoring, alarm functionality and compressor shutdown, and uses a Hall sensor to measure the oil level. A magnetic float changes its position according to the oil level. The Hall sensor converts these magnetic field changes into an equivalent signal. The electronic controller converts that signal into the LED display that shows oil level. If the oil level drops into the red zone, the OW3 generates an alarm signal and the alarm contact changes into alarm state. The latter may be used to shut down the compressor. If the oil level comes back to normal, the alarm is reset.

Part Number	Model
83001001	OW3-01
83001002	OW3-02

Optional Items

Pressure Differential Indicator (PDI)

Temprite's Pressure Differential indicator (PDI) lets you know when the filter inside a Temprite 920 or 920R Series coalescent oil separator should be changed.



- A dirt-laden filter can severely affect the performance of a 920 or 920R Series oil separator.
- Mounted atop or next to the Temprite 920 or 920R Series coalescent oil separator, the PDI measures the difference in pressure between the inlet and the outlet of the separator.
- If the PDI shows 11 to 13 PSID differential pressure, it's time to change the filter.

Part Number	Model #	Connection	Electric	Max. Working Press.
022400000	224	1/4" SAE	60 W 3 A 24v N.O.	650 PSI

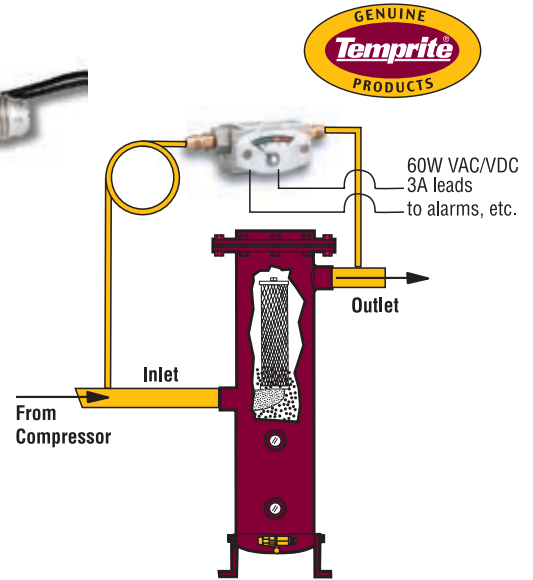

Filter/Drier Shells for CO₂

Maximum Working Pressure: 130 bar (1885 PSI)

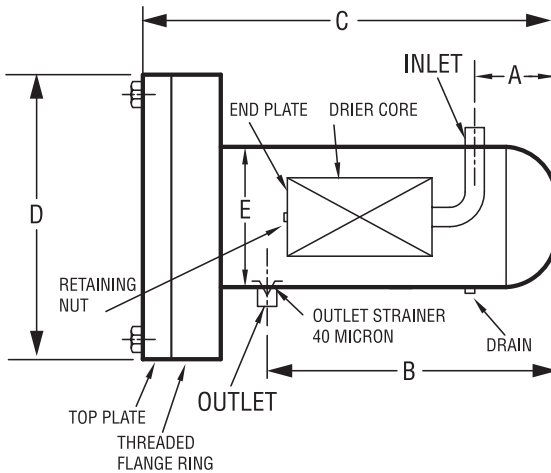

48-1

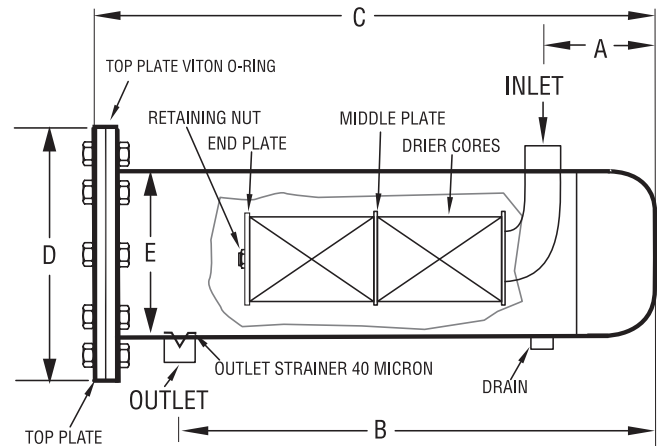

48-2

Part #	Model #	Inlet/ Outlet Conn.	Drain Conn.	A Dim.	B Dim.	C Dim.	D Dim.	E Dim.
				Inlet	Outlet	Overall Length	Flange Diameter	Shell Diameter
013701148	48-1	1-1/4" BW*	1/4" FPT*	117 mm 4-5/8"	384 mm 15-1/8"	500 mm 19-11/16"	216 mm 8-1/2"	141 mm 5-9/16"
013701248	48-2	1-1/4" BW*	1/4" FPT*	117 mm 4-5/8"	524 mm 20-5/8"	639 mm 25-1/8"	216 mm 8-1/2"	141 mm 5-9/16"

* FPT=Female Pipe Thread, MPT=Male Pipe Thread, BW=Butt Weld

Filter Kits



Temprite Filtration Technology

Temprite coalescent oil separators employ a matrix-type borosilicate filter to do the work formerly done by impingement screens. The exceptionally pure, extremely fine glass fibers in the filter cause the oil molecules to collide, creating bigger droplets, until each is large enough to be forced to the outer drain layer of the filter. The droplets fall to the bottom of the separator and the oil is returned to the compressor.

The biggest energy drains on any refrigeration system are dirt, contaminants and excess refrigerant oil. New refrigerants coming onto the market have an enhanced solvent effect, meaning more contaminants than ever can be clogging your system. Solid contaminants in the system are harmful to sensors and other delicate components. Eliminating solid contaminants and excess oil from the system enhances the entire system's performance:

- The exceptional Temprite Standard Filter is finer than any other filter/drier, picking up all effluent and dirt in the system down to 0.3 microns in size, increasing system efficiency and lowering energy costs.
- Thermostatic Expansion Valves (TXV) work more efficiently.
- Desiccant in filter dryers is more effective when not logged with oil that prevents moisture from being absorbed.

Temprite®130 Series Replacement Filter Kits

Standard Filter Kits

Part Number	For Model	A Nominal	B Nominal
62021133	133A	1"	5"
62021135	135A	2"	9"
62021137	137A	3.5"	14"
62021138	138A	3.5"	20"
62021139	139A	5.1"	19"

*O-Ring included

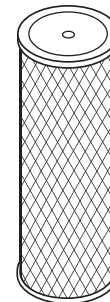

Standard

Clean Up Burnouts with a Temprite Clean-Up® Filter

Another advantage of Temprite coalescent oil separators is that, should the compressor burn out, all effluent is localized in the separator, sparing delicate metering devices from a rush of burnt particles.

After a burnout in an accessible coalescent oil separator, simply install a Temprite Clean-Up® Filter to purge the system of contaminants. Using a Clean-Up® Filter in conjunction with a coalescent oil separator can return the oil to near-virgin state.

Clean-Up® Filter Kits

Part Number	For Model	A Nominal	B Nominal
62022133	133A	1"	5"
62022135	135A	2"	9"
62022137	137A	3.5"	14"
62021138	138A	3.5"	20"
62022139	139A	5.1"	19"

*O-Ring included



Clean-Up®

Replacement Parts

Temprite® 920 & 920R Series Filter Kits



Standard Filter Kits

Part #	For Model	A Nominal	B Nominal
62034000	922*, 923*, 922R*, 923R*	1"	5"
62037000	924*, 925*, 924R*, 925R*	2"	9"
62028000	926+, 927+, 926R+, 927R+	3-1/2"	14"
62051000	928!, 928R!	5-1/8"	16"
62085000	930!, 930R!	8-1/2"	16"

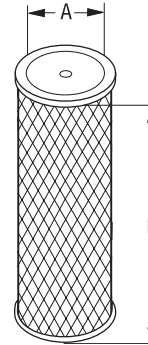

Clean-Up® Filter Kits

Part #	For Model	A Nominal	B Nominal
62024000	922*, 923*, 922R*, 923R*	1"	5"
62047000	924*, 925*, 924R*, 925R*	2"	9"
62030000	926+, 927+, 926R+, 927R+	3-1/2"	14"
62092802	928!, 928R!	5-1/8"	16"
62086000	930!, 930R!	8-1/2"	16"

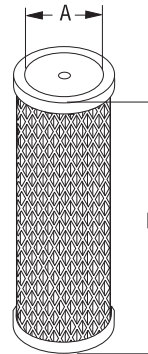

* Kit includes Filter, Gasket and Sealing Washer

+ Kit includes Filter, Gasket, O-Ring and Sealing Washer

! Kit includes Filter, two (2) different size O-Rings and Sealing Washer

Screen Kits

Part #	For Model
60001000	501*
60002000	502*
60003000	503*
60004000	504*
60005000	505*
60006000	506
60007000	507

* 2 Screens Included

Gasket Included in all Kits

4" Bottom Plate Gaskets & 4" Top Plate Gaskets

Part #	For Model	Quantity
55000010	501-507, 922-930	10 Pack

6" Top Plate Gaskets/O-Rings

Part #	For Model	Quantity
55100005*	926, 927, 926R, 927R	5 Pack

*(5) each O-Rings and Gaskets

O-Ring/Gasket Kits

Part #	For Model
55928000	928, 928R
55930000	930, 930R

Kit contains (1) Large, (1) Small O-Ring and (1) 4" Gasket

O-Rings

Part #	For Model
55881135 (-338)	133A, 135A
55881137 (-350)	137A, 138A, 48-2, 48-1
55881139 (-365)	139A
55881148 (-350)	48-2, 48-1 (Viton option)

Float & Plate Assemblies

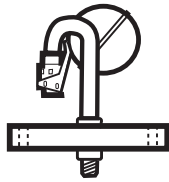

Part # 52200000

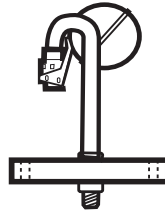

Part # 52300000

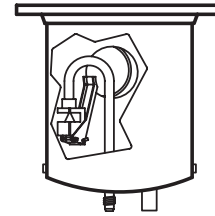

Part # 059260000D

Part Number	Description	For Model
51100000*	Flt/Ndl Assy	501-505
51200000*	Flt/Ndl Assy	506, 507
52200000*	Flt/Plt Assy w/Btm Plt w/Drain	506, 507, 926 (Top Load), 927 (Top Load)
52300000*	Flt/Plt Assy w/Btm Plt w/Drain	508-510, 928, 930
059260000D*	Btm Dome Assy w/Drain	926 (Old Style), 927 (Old Style)

* Gasket Included.

Sight Glasses

Part Number	For Model
76115000	15/16"-20THRD (Marked)
76116000	1-1/8"-18THRD (Unmarked)
76118000	3/4" NPT THRD w/ Float Ball 650 PSI (Unmarked)
76118130	3/4" NPT THRD w/ Float Ball (Marked) No O-Ring 1885 PSI



Part # 76118130



Temprite® 920 & 920R Series Coalescent Oil Separators

- **Energy Efficient = Clean & Green**
 - Lowers Energy Costs
 - Reduces Carbon Emissions
- **Compatible with All Refrigerants**
 - CO₂ and NH₃ (Ammonia)*
- **Unique Filter Technology**
 - Cleans Contaminants Down to 0.3 Microns

* CO₂ Subcritical applications up to 44.8 Bar,
NH₃ applications up to 650 PSI



Model 927R

Model 926

1-800-552-9300/630-293-5910

www.temprite.com

email: temprite@temprite.com

Distributed by:

Temprite®

1555 West Hawthorne Lane, Suite 1E
West Chicago, Illinois 60185-1822 USA
Phone: 630.293.5910
Fax: 630.293.9594
email: temprite@temprite.com

Specifications subject to change without notice.

Copyright © 2013 Temprite. All Rights Reserved 12/10